

Dimensions [mm]				approx. weight per 100 pieces [kg]	Permissible load			
Mild steel (bk) / Galvanised + chromated steel (zn)					Axial pull	Inclined pull S_{Rd}		90° pull
					N_{Rd}	$B_{Rd} \leq 30^\circ$	$B_{Rd} \leq 45^\circ$	V_{Rd}
d x L	Order No.	g	s		[kN]			
M 5 x 40	k1105bk/zn	5	22	1.00	1.9	1.4	0.9	0.6
M 6 x 40	k1110bk/zn	6	20	1.00	2.4	1.7	1.3	0.8
M 6 x 50	k1111bk/zn	6	30	1.20	2.7	2.1	1.4	0.9
M 6 x 60	k1112bk/zn	6	40	1.45	2.9	2.2	1.6	0.9
M 8 x 40	k1115bk/zn	8	15	1.20	3.2	2.4	1.6	1.1
M 8 x 50	k1116bk/zn	8	25	1.65	3.5	2.7	1.9	1.1
M 8 x 60	k1117bk/zn	8	35	1.93	3.8	3.0	2.1	1.3
M 8 x 80	k1118bk/zn	8	55	2.40	4.3	3.5	2.2	1.3
M 8 x 100	k1119bk/zn	8	75	3.20	4.8	3.8	2.5	1.4
M 10 x 40	k1125bk/zn	10	15	1.60	3.5	2.7	1.7	1.1
M 10 x 50	k1126bk/zn	10	25	2.00	4.3	3.2	2.2	1.3
M 10 x 60	k1127bk/zn	10	35	2.38	5.3	4.1	2.5	1.6
M 10 x 80	k1128bk/zn	10	55	3.23	5.4	4.3	2.9	1.6
M 10 x 100	k1129bk/zn	10	75	3.98	5.6	4.5	3.0	1.7
M 10 x 60 *	k1135bk/zn	10	32	3.90	7.2	6.4	5.6	4.0
M 12 x 60	k1140bk/zn	12	28	3.50	6.4	4.8	3.5	2.2
M 12 x 80	k1141bk/zn	12	48	4.32	6.7	4.9	3.7	2.4
M 12 x 100	k1142bk/zn	12	68	5.60	7.0	5.3	3.8	2.5
M 12 x 120	k1143bk/zn	12	88	6.80	7.2	5.4	4.0	2.5
M 12 x 50 *	k1150bk/zn	12	20	3.97	8.0	6.4	5.6	4.0
M 12 x 70 *	k1151bk/zn	12	40	5.46	9.6	7.2	6.4	4.8
M 12 x 100 *	k1152bk/zn	12	70	7.74	10.4	8.0	7.2	5.1
M 16 x 60	k1159bk/zn	15	20	7.80	10.4	8.0	7.2	5.6
M 16 x 70	k1160bk/zn	15	25	9.12	12.8	10.4	9.6	6.4
M 16 x 80	k1161bk/zn	15	35	10.43	13.6	11.2	9.6	6.9
M 16 x 100	k1162bk/zn	15	55	12.50	16.0	12.8	11.2	8.0
M 16 x 120	k1163bk/zn	15	75	15.40	16.0	13.6	12.0	8.0
M 16 x 150	k1164bk/zn	15	105	18.90	17.6	14.4	12.8	8.8
M 20 x 90	k1170bk/zn	18	25	17.00	17.6	14.4	12.8	9.6
M 20 x 100	k1171bk/zn	18	45	19.00	20.8	16.0	15.2	10.4
M 20 x 120	k1172bk/zn	18	65	22.20	22.4	17.6	16.0	11.2
M 20 x 150	k1173bk/zn	18	95	28.30	24.0	19.2	17.6	12.0
M 24 x 105	k1180bk/zn	21	40	26.70	25.6	20.8	17.6	12.8
M 24 x 120	k1181bk/zn	21	55	30.70	27.2	22.4	19.2	13.6
M 27 x 130	k1185bk/zn	22	50	42.00	35.2	28.8	24.0	17.6
M 30 x 150	k1187bk/zn	23	75	72.70	48.0	38.4	33.6	24.0

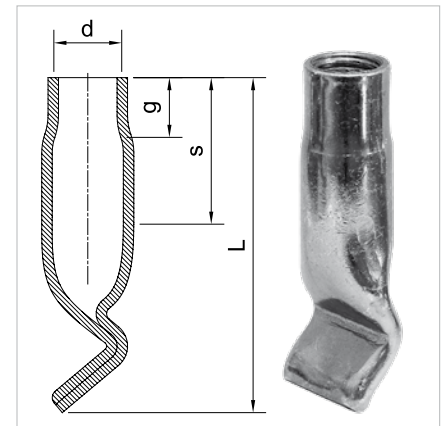

On request our fixing sockets can be given a 4-6 μm electrogalvanic coating plus yellow chromate conversion coating.

The thread is cut oversize.
The loads were determined by pullout tests carried out in unreinforced C 20/25 concrete with loads applied axially and at angles of up to 90° at government materials-testing laboratories.

Installation situation:
Tension: edge distance $c_{cr} = 1.5 \times L$
Shear: edge distance $c_{cr} = 2 \times L$
Min. element thk. $h_{min} = L + c_{mon}$

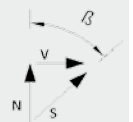

Items marked with * are fabricated from tubes with thicker walls and have a higher load-carrying capacity.

The fixing socket is used as a permanent fixture and complies with the requirements of the Construction Products Regulation (CE marking, declaration of conformity to DIN EN 1090).

Custom versions on request.
Errors and omissions excepted.
Position as of Jan 2015

Dimensions [mm]				approx. weight per 100 pieces [kg]	Permissible load			
Stainless steel grade A4					Axial pull	Inclined pull S_{Rd}		90° pull
					N_{Rd}	$B_{Rd} \leq 30^\circ$	$B_{Rd} \leq 45^\circ$	V_{Rd}
d x L	Order No.	g	s		[kN]			
M 8 x 40	k1115va	9	15	1.60	3.2	2.4	1.6	1.1
M 8 x 60	k1117va	9	35	2.60	3.8	3.0	2.1	1.3
M 10 x 50	k1126va	10	25	2.26	4.3	3.2	2.2	1.3
M 10 x 60	k1127va	10	35	2.80	5.3	4.1	2.5	1.6
M 10 x 80	k1128va	10	55	3.58	5.4	4.3	2.9	1.6
M 10 x 60*	k1135va	11	32	3.70	7.2	6.4	5.6	4.0
M 12 x 60	k1140va	12	30	3.15	6.4	4.8	3.5	2.2
M 12 x 80	k1141va	12	50	4.40	6.7	4.9	3.7	2.4
M 12 x 100	k1142va	12	70	5.20	7.2	5.3	3.8	2.5
M 12 x 50*	k1150va	12	12	3.90	8.0	6.4	5.6	4.0
M 12 x 70*	k1151va	12	30	5.55	9.6	7.2	6.4	4.8
M 16 x 70	k1160va	15	25	8.67	12.8	10.4	9.6	6.4
M 16 x 80	k1161va	15	35	9.75	13.6	11.2	9.6	6.9
M 16 x 100	k1162va	15	55	12.36	16.0	12.8	11.2	8.0
M 20 x 90	k1170va	18	25	15.53	17.6	14.4	12.8	9.6
M 20 x 100	k1171va	18	40	17.25	20.8	16.0	15.2	10.4
M 24 x 105	k1180va	21	40	29.00	25.6	20.8	17.6	12.8
M 24 x 120	k1181va	21	55	33.95	27.2	22.4	19.2	13.6

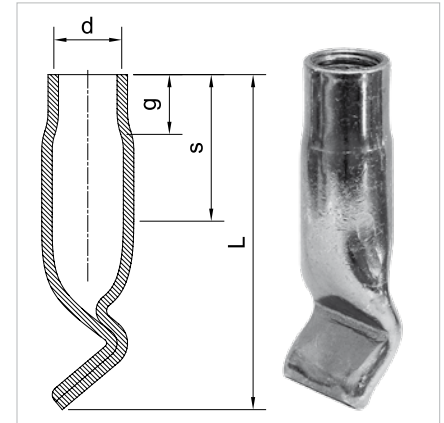

The thread is cut oversize.

The loads were determined by pullout tests carried out in unreinforced C 20/25 concrete with loads applied axially and at angles of up to 90° at government materials-testing laboratories.

Installation situation:

Tension: edge distance $c_{cr} = 1.5 \times L$

Shear: edge distance $c_{cr} = 2 \times L$

Min. element thk. $h_{min} = L + c_{mon}$

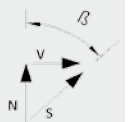

Items marked with * are fabricated from tubes with thicker walls and have a higher load-carrying capacity.

The fixing socket is used as a permanent fixture and complies with the requirements of the Construction Products Regulation (CE marking, declaration of conformity to DIN EN 1090).

Custom versions on request.
Errors and omissions excepted.
Position as of Jan 2015

Dimensions [mm]					approx. weight per 100 pieces	Permissible load			
Mild steel (bk) / Galvanised + chromated steel (zn)						Axial pull	Inclined pull S_{Pd}		90° pull
						N_{Pd}	$B_{Pd} \leq 30^\circ$	$B_{Pd} \leq 45^\circ$	V_{Pd}
d x L	Order No.	g	s	e	[kg]	[kN]			
M 8 x 40	k1215bk/zn	8	15	8.3	1.20	3.2	2.4	1.6	1.1
M 8 x 50	k1216bk/zn	8	25	8.3	1.54	3.5	2.7	1.9	1.1
M 8 x 60	k1217bk/zn	8	35	8.3	1.80	3.8	3.0	2.1	1.3
M 8 x 80	k1218bk/zn	8	55	8.3	2.50	4.3	3.5	2.2	1.3
M 8 x 100	k1219bk/zn	8	75	8.3	3.26	4.8	3.8	2.5	1.4
M 10 x 40	k1225bk/zn	10	15	8.3	1.49	3.5	2.7	1.7	1.1
M 10 x 50	k1226bk/zn	10	25	8.3	1.90	4.3	3.2	2.2	1.3
M 10 x 60	k1227bk/zn	10	35	8.3	2.25	5.3	4.1	2.5	1.6
M 10 x 80	k1228bk/zn	10	55	8.3	2.96	5.4	4.3	2.9	1.6
M 10 x 100	k1229bk/zn	10	75	8.3	3.78	5.6	4.5	3.0	1.7
M 10 x 60*	k1235bk/zn	10	32	8.3	3.79	7.2	6.4	5.6	4.0
M 12 x 60	k1240bk/zn	12	28	8.3	3.07	6.4	4.8	3.5	2.2
M 12 x 80	k1241bk/zn	12	48	8.3	4.40	6.7	4.9	3.7	2.4
M 12 x 100	k1242bk/zn	12	68	8.3	5.47	7.0	5.3	3.8	2.5
M 12 x 120	k1243bk/zn	12	88	8.3	6.67	7.2	5.4	4.0	2.5
M 12 x 50*	k1250bk/zn	12	20	8.3	3.83	8.0	6.4	5.6	4.0
M 12 x 70*	k1251bk/zn	12	40	8.3	5.48	9.6	7.2	6.4	4.8
M 12 x 100*	k1252bk/zn	12	70	8.3	7.49	10.4	8.0	7.2	5.1
M 16 x 70	k1260bk/zn	15	25	10.3	9.81	12.8	10.4	9.6	6.4
M 16 x 80	k1261bk/zn	15	35	10.3	10.57	13.6	11.2	9.6	6.9
M 16 x 100	k1262bk/zn	15	55	10.3	12.00	16.0	12.8	11.2	8.0
M 16 x 120	k1263bk/zn	15	75	10.3	16.66	16.0	13.6	12.0	8.0
M 16 x 150	k1264bk/zn	15	105	10.3	18.84	17.6	14.4	12.8	8.8
M 20 x 90	k1270bk/zn	18	25	12.3	16.44	17.6	14.4	12.8	9.6
M 20 x 100	k1271bk/zn	18	45	12.3	18.26	20.8	16.0	15.2	10.4
M 20 x 120	k1272bk/zn	18	65	12.3	21.99	22.4	17.6	16.0	11.2
M 20 x 150	k1273bk/zn	18	95	12.3	27.14	24.0	19.2	17.6	12.0
M 24 x 105	k1280bk/zn	21	40	14.3	25.62	25.6	20.8	17.6	12.8
M 24 x 120	k1281bk/zn	21	55	14.3	29.21	27.2	22.4	19.2	13.6
M 30 x 150	k1287bk/zn	23	75	14.3	71.63	48.0	38.4	33.6	24.0

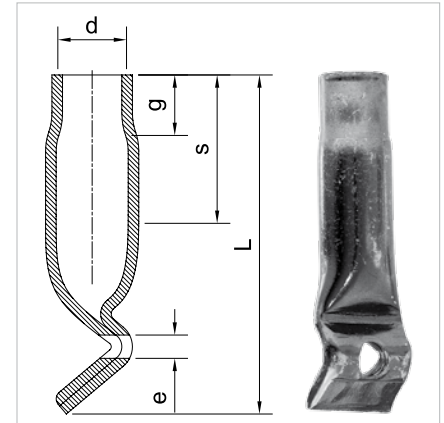

On request our fixing sockets can be given a 4-6 µm electrogalvanic coating plus yellow chromate conversion coating.

The thread is cut oversize.
The loads were determined by pullout tests carried out in unreinforced C 20/25 concrete with loads applied axially and at angles of up to 90° at government materials-testing laboratories.

Installation situation:
Tension: edge distance $c_{cr} = 1.5 \times L$
Shear: edge distance $c_{cr} = 2 \times L$
Min. element thk. $h_{min} = L + c_{mon}$

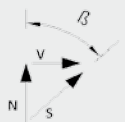

Items marked with * are fabricated from tubes with thicker walls and have a higher load-carrying capacity.

The fixing socket is used as a permanent fixture and complies with the requirements of the Construction Products Regulation (CE marking, declaration of conformity to DIN EN 1090).

Custom versions on request.
Errors and omissions excepted.
Position as of Jan 2015

Dimensions [mm] Mild steel (bk) / Galvanised + chromated steel (zn)				Nailing plate type	approx. weight per 100 pieces [kg]	Permissible load			
d x L	Order No.	g	s			Axial pull	Inclined pull S_{Pd}	90° pull	
						N_{Pd}	$B_{Pd} \leq 30^\circ$	$B_{Pd} \leq 45^\circ$	V_{Pd}
						[kN]			
M 6 x 40	k1310bk/zn	6	20	A	2.70	2.4	1.7	1.3	0.8
M 8 x 60	k1317bk/zn	8	35	A	3.75	3.8	3.0	2.1	1.3
M 10 x 60	k1327bk/zn	10	35	A	4.25	5.3	4.1	2.5	1.6
M 10 x 100	k1329bk/zn	10	75	A	5.70	5.6	4.5	3.0	1.7
M 10 x 60*	k1335bk/zn	10	32	A	5.25	7.2	6.4	5.6	4.0
M 12 x 60	k1340bk/zn	12	28	A	5.05	6.4	4.8	3.5	2.2
M 12 x 100	k1342bk/zn	12	68	A	7.22	7.2	5.3	3.8	2.5
M 12 x 70*	k1351bk/zn	12	40	A	7.15	9.6	7.2	6.4	4.8
M 16 x 60	k1359bk/zn	15	20	A	9.07	10.4	8.0	7.2	5.6
M 16 x 70	k1360bk/zn	15	25	A	10.55	12.8	10.4	9.6	6.4
M 16 x 80	k1361bk/zn	15	35	A	13.10	13.6	11.2	9.6	6.9
M 16 x 100	k1362bk/zn	15	55	A	15.40	16.0	12.8	11.2	8.0
M 20 x 90	k1370bk/zn	18	25	B1	20.69	17.6	14.4	12.8	9.6
M 20 x 100	k1371bk/zn	18	45	B1	22.62	20.8	16.0	15.2	10.4
M 24 x 105	k1380bk/zn	21	40	B1	30.17	25.6	20.8	17.6	12.8
M 30 x 150	k1387bk/zn	23	75	B2	78.45	48.0	38.4	33.6	24.0

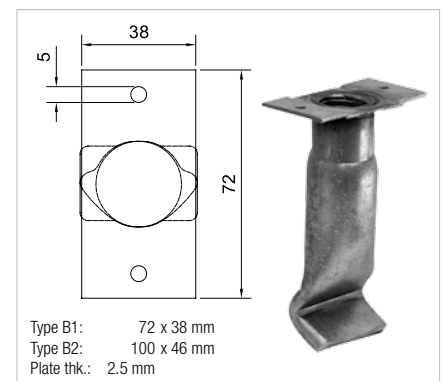
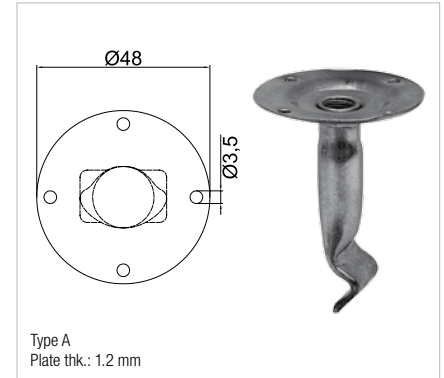

On request our fixing sockets can be given a 4-6 μ m electrogalvanic coating plus yellow chromate conversion coating.

The thread is cut oversize.

The loads were determined by pullout tests carried out in unreinforced C 20/25 concrete with loads applied axially and at angles of up to 90° at government materials-testing laboratories.

Installation situation:

Tension: edge distance $c_{cr} = 1.5 \times L$

Shear: edge distance $c_{cr} = 2 \times L$

Min. element thk. $h_{min} = L + c_{mon}$

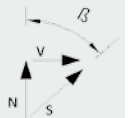

Items marked with * are fabricated from tubes with thicker walls and have a higher load-carrying capacity.

The fixing socket is used as a permanent fixture and complies with the requirements of the Construction Products Regulation (CE marking, declaration of conformity to DIN EN 1090).

The nailing plate enables the socket to be easily attached to timber formwork.

Custom versions on request.
Errors and omissions excepted.
Position as of Jan 2015



Fixing socket

with bent end in steel or stainless steel grade A4

15

Dimensions [mm]				approx. weight per 100 pieces [kg]	Permissible load	
Mild steel (bk) / Galvanised + chromated steel (zn)					Axial pull	90° pull
d x L x h	Order No.	g	s		N _{Rd}	V _{Rd}
M 8 x 30 x 20	k1508bk/zn	8	16	1.32	2.6	2.5
M 10 x 35 x 21	k1510bk/zn	10	20	2.00	3.4	3.2
M 12 x 45 x 25	k1512bk/zn	12	20	3.40	5.4	4.6
M 16 x 60 x 30	k1516bk/zn	15	32	9.91	8.8	7.1
M 20 x 70 x 30	k1520bk/zn	18	28	16.30	11.7	9.0
M 24 x 80 x 37	k1524bk/zn	21	30	25.60	15.1	11.1

Dimensions [mm]				approx. weight per 100 pieces [kg]	Permissible load	
Stainless steel grade A4					Axial pull	90° pull
d x L x h	Order No.	g	s		N _{Rd}	V _{Rd}
M 8 x 30 x 20	k1508va	9	12	1.30	2.6	2.5
M 10 x 35 x 21	k1510va	10	18	2.00	3.4	3.2
M 12 x 45 x 25	k1512va	12	20	3.50	5.4	4.6
M 16 x 60 x 30	k1516va	15	22	9.50	8.8	7.1
M 20 x 70 x 30	k1520va	18	22	16.00	11.7	9.0
M 24 x 80 x 37	k1524va	21	30	25.60	15.1	11.1

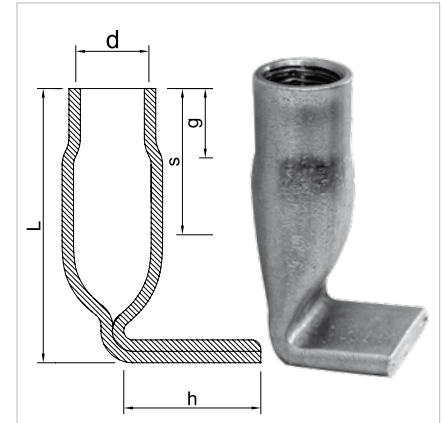

On request our fixing sockets can be given a 4-6 µm electrogalvanic coating plus yellow chromate conversion coating.

The thread is cut oversize.
The loads were determined by pullout tests carried out in unreinforced C 20/25 concrete with loads applied axially and at angles of up to 90° at government materials-testing laboratories.

Installation situation:
Tension: edge distance $c_{cr} = 1.5 \times L$
Shear: edge distance $c_{cr} = 2 \times L$
Min. element thk. $h_{min} = L + c_{mon}$

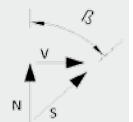

The fixing socket is used as a permanent fixture and complies with the requirements of the Construction Products Regulation (CE marking, declaration of conformity to DIN EN 1090).

The following applies in the case of axial and transverse loads acting simultaneously
 $N_{Sd} \text{ and } V_{Sd} : N_{Sd} / N_{Rd} + V_{Sd} / V_{Rd} \leq 1.20$

Custom versions on request.
Errors and omissions excepted.
Position as of Jan 2015



Dimensions [mm]	Electrogalvanised socket Mild steel crosspin S 235 JR		Stainless steel grade 1.4571 or 1.4404 Mild steel crosspin S 235 JR		approx. weight per 100 pieces	approx. weight per 100 pieces
	without nailing plate	with nailing plate	without nailing plate	with nailing plate	without nailing plate	with nailing plate
d x L	Order No.	Order No.	Order No.	Order No.	[kg]	[kg]
M 8 x 53	k2008zn	k2008znp	k2008va	k2008vap	3.00	4.10
M 10 x 68	k2010zn	k2010znp	k2010va	k2010vap	6.00	7.50
M 12 x 81	k2012zn	k2012znp	k2012va	k2012vap	8.80	9.88
M 16 x 106	k2016zn	k2016znp	k2016va	k2016vap	18.37	20.00
M 20 x 129	k2020zn	k2020znp	k2020va	k2020vap	30.00	33.90
M 24 x 166	k2024zn	k2024znp	k2024va	k2024vap	51.60	56.63

Dimensions: steel/stainless steel sockets

Dimensions [mm]					
d x L	g	s	L ₁	h	d ₂
M 8 x 53	8.0/9.0	28.0	25.0	40.0	8.0
M 10 x 68	10.0	35.0/33.0	35.0	50.0	10.0
M 12 x 81	12.0	43.0	35.0	60.0	12.0
M 16 x 106	16.0	55.0	50.0	80.0	12.0
M 20 x 129	20.0	68.0	60.0	100.0	14.0
M 24 x 166	24.0	85.0	75.0	125.0	14.0

Loads: permissible loads in cracked and uncracked concrete

d x L	Cracked concrete		Uncracked concrete			
			Dense reinforcement		Reinforcement c/c spacing ≤ 15 cm	
	permF ₁ [kN]	permF ₂ [kN]	permF ₂ [kN]	permF ₂ [kN]	permF ₃ [kN]	permF ₃ [kN]
M 8 x 53	C 12/15	C 20/25	C 12/15	C 20/25	C 12/15	C 20/25
M 8 x 53	1.0	1.5	1.7	2.5	2.0	3.0
M 10 x 68	1.7	2.5	2.9	4.2	3.9	5.7
M 12 x 81	2.4	3.5	4.0	5.9	5.0	7.3
M 16 x 106	4.5	6.0	7.1	10.2	8.0	11.4
M 20 x 129	6.3	9.0	10.7	15.3	11.3	16.2
M 24 x 166	9.1	13.0	15.4	22.1	15.4	22.1

Valid for: $F_{Rd} = 1.4 \times \text{perm}F_1$ or $\text{perm}F_2$

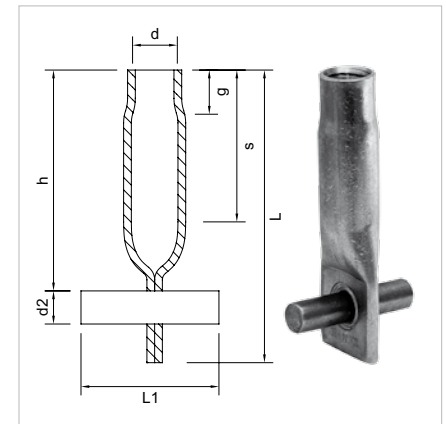

Approved for use in cracked and uncracked concrete, Z-21.4-87 DIBt, Berlin.

Individual or groups of sockets have been approved for applications in cracked and uncracked concrete. The National Technical Approval enables loadbearing, structural connections to be provided right from the casting of the concrete component. It is no longer necessary to drill through reinforcement and damage the structure of the concrete in order to install expanding anchors.

The information given in DIBt approval Z-21.4-87 must be followed in addition to the information given on this sheet of the catalogue.

The fixing socket with crosspin is approved by the German Institute of Building Technology (DIBt), Berlin, for predominantly static loads in reinforced or unreinforced concrete of grade C 12/15 or higher.

Stainless steel may have to be used depending on the application.

Forms: with or without nailing plate. Steel crosspins are pressed in place, dimensions are given in the table.

Errors and omissions excepted.
Position as of Jan 2015

Dimensions [mm]					approx. weight per 100 pieces [kg]	Permissible load ¹⁾			
Mild steel (bk) / Galvanised + chromated steel (zn)						Axial pull	Inclined pull S_{Pd}		90° pull
						N_{Pd}	$B_{Pd} \leq 30^\circ$	$B_{Pd} \leq 45^\circ$	V_{Pd}
d x L	Order No.	g	s	e	[kN]				
M 6 x 35	k2109bk/zn	6	15	6.3	0.80	2.4	1.9	1.4	0.8
M 8 x 40	k2115bk/zn	8	15	8.3	1.05	3.8	3.2	2.4	1.6
M 8 x 53	k2117bk/zn	8	28	8.3	1.38	3.8	3.2	2.4	1.6
M 10 x 45	k2124bk/zn	10	15	10.3	1.50	4.6	3.7	2.7	1.6
M 10 x 57	k2127bk/zn	10	25	10.3	2.00	4.6	3.7	2.7	1.6
M 10 x 57*	k2135bk/zn	10	24	10.3	3.00	7.2	6.4	4.8	4.0
M 12 x 55	k2139bk/zn	12	20	12.3	2.60	7.0	5.9	4.0	2.4
M 12 x 78	k2141bk/zn	12	43	12.3	4.00	9.6	8.0	6.4	5.6
M 12 x 62*	k2149bk/zn	12	25	12.3	4.03	12.5	10.4	8.3	7.3
M 16 x 80	k2161bk/zn	15	30	12.3	9.82	20.8	17.6	14.4	12.8
M 16 x 100	k2162bk/zn	15	50	12.3	11.53	20.8	17.6	14.4	12.8
M 16 x 120	k2163bk/zn	15	70	12.3	14.65	20.8	17.6	14.4	12.8
M 20 x 95	k2171bk/zn	18	35	14.3	16.50	27.2	24.0	20.8	14.4
M 20 x 115	k2172bk/zn	18	55	14.3	20.00	27.2	24.0	20.8	14.4
M 24 x 120	k2181bk/zn	21	40	14.3	28.60	32.0	27.2	24.0	16.0
M 27 x 135	k2185bk/zn	22	47	17.3	49.60	43.2	36.8	33.6	19.2
M 30 x 150	k2187bk/zn	23	65	17.3	68.60	62.4	51.2	40.0	20.8

¹⁾ The loads given here can only be achieved when using U-bar anchorages in reinforcing steel grade B500B with the following dimensions [mm]:

U-bar anchorage B500B [mm]			
d	d _s	D _{min}	G
M 10	8	60	250
M 12	10	60	300
M 16	10	70	350
M 20	12	80	400
M 24	12	80	450
M 27	14	100	500
M 30	14	100	600

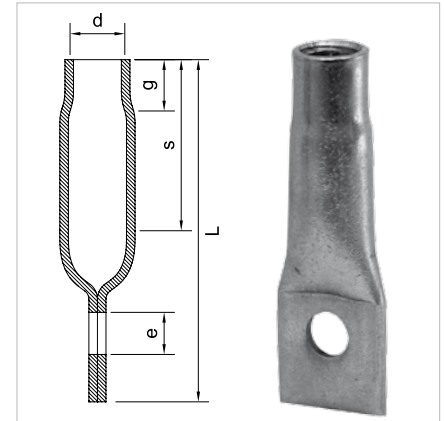
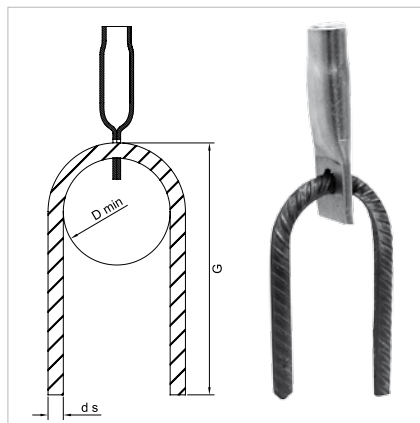

On request our fixing sockets can be given a 4-6 µm electrogalvanic coating plus yellow chromate conversion coating.

The thread is cut oversize.
The loads were determined by pullout tests carried out in unreinforced C 20/25 concrete with loads applied axially and at angles of up to 90° at government materials-testing laboratories.

Installation situation:
Tension: edge distance $c_{cr} = 1.5 \times L$
Shear: edge distance $c_{cr} = 2 \times L$
Min. element thk. $h_{min} = L + c_{mon}$

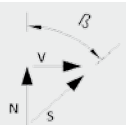

Items marked with * are fabricated from tubes with thicker walls and have a higher load-carrying capacity.

The fixing socket is used as a permanent fixture and complies with the requirements of the Construction Products Regulation (CE marking, declaration of conformity to DIN EN 1090).

Custom versions on request.
Errors and omissions excepted.
Position as of Jan 2015

Dimensions [mm]					approx. weight per 100 pieces [kg]	Permissible load ¹⁾			
Stainless steel grade A4						Axial pull	Inclined pull S_{Rd}	90° pull	
						N_{Rd}	$B_{Rd} \leq 30^\circ$	$B_{Rd} \leq 45^\circ$	V_{Rd}
d x L	Order No.	g	s	e		[kN]			
M 8 x 40	k2115va	9	10	8.3	1.43	3.8	3.2	2.4	1.6
M 8 x 53	k2117va	9	23	8.3	1.95	3.8	3.2	2.4	1.6
M 10 x 45	k2124va	10	15	10.3	1.75	4.6	3.7	2.7	1.6
M 10 x 57	k2127va	10	25	10.3	2.27	4.6	3.7	2.7	1.6
M 10 x 57*	k2135va	10	24	10.3	3.10	7.2	6.4	4.8	4.0
M 12 x 55	k2139va	12	20	12.3	2.60	7.0	5.9	4.0	2.4
M 12 x 78	k2141va	12	43	12.3	3.53	9.6	8.0	6.4	5.6
M 12 x 62*	k2149va	12	25	12.3	4.00	12.5	10.4	8.3	7.3
M 16 x 80	k2161va	15	30	12.3	8.45	20.8	17.6	14.4	12.8
M 16 x 100	k2162va	15	50	12.3	10.72	20.8	17.6	14.4	12.8
M 20 x 95	k2171va	18	28	14.3	15.53	27.2	24.0	20.8	14.4
M 20 x 115	k2172va	18	50	14.3	19.15	27.2	24.0	20.8	14.4
M 24 x 120	k2181va	21	40	14.3	29.58	32.0	27.2	24.0	16.0

¹⁾ The loads given here can only be achieved when using U-bar anchorages in reinforcing steel grade B500B with the following dimensions [mm]:

U-bar anchorage B500B [mm]			
d	d _s	D _{min}	G
M 10	8	60	250
M 12	10	60	300
M 16	10	70	350
M 20	12	80	400
M 24	12	80	450
M 27	14	100	500
M 30	14	100	600

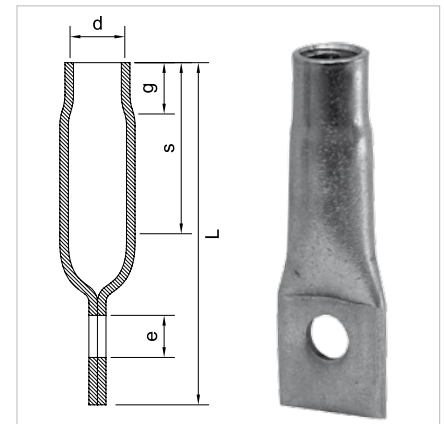
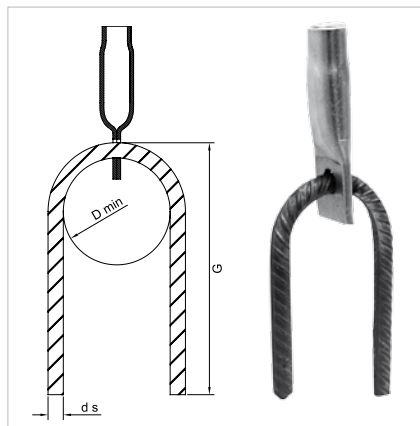

The thread is cut oversize.
The loads were determined by pullout tests carried out in unreinforced C 20/25 concrete with loads applied axially and at angles of up to 90° at government materials-testing laboratories.

Installation situation:
Tension: edge distance $c_{cr} = 1.5 \times L$
Shear: edge distance $c_{cr} = 2 \times L$
Min. element thk. $h_{min} = L + c_{mon}$

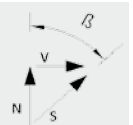

Items marked with * are fabricated from tubes with thicker walls and have a higher load-carrying capacity.

The fixing socket is used as a permanent fixture and complies with the requirements of the Construction Products Regulation (CE marking, declaration of conformity to DIN EN 1090).

Custom versions on request.
Errors and omissions excepted.
Position as of Jan 2015

Dimensions [mm]				approx. weight per 100 pieces [kg]	Permissible load			
Mild steel (bk) / Galvanised + chromated steel (zn)					Axial pull	Inclined pull S_{Rd}		90° pull
					N_{Rd}	$B_{Rd} \leq 30^\circ$	$B_{Rd} \leq 45^\circ$	V_{Rd}
d x L	Order No.	d ₂	L ₁		[kN]			
M 8 x 40	k2215bk/zn	8	50	3.10	3.2	2.5	1.9	1.1
M 8 x 53	k2217bk/zn	8	50	3.50	3.5	2.9	2.1	1.3
M 10 x 45	k2224bk/zn	10	60	5.25	4.1	3.5	2.2	1.3
M 10 x 57	k2227bk/zn	10	60	5.70	4.9	4.0	2.7	1.4
M 10 x 57*	k2235bk/zn	10	70	7.60	8.0	6.4	5.6	3.2
M 12 x 55	k2239bk/zn	12	70	8.75	7.8	6.4	3.7	2.4
M 12 x 78	k2241bk/zn	12	70	10.00	10.4	8.0	7.2	4.0
M 12 x 62*	k2249bk/zn	12	70	10.45	10.4	8.0	7.2	4.0
M 16 x 80	k2261bk/zn	12	100	17.85	14.4	12.0	10.4	6.4
M 16 x 100	k2262bk/zn	12	100	20.47	16.0	12.8	11.2	6.4
M 16 x 120	k2263bk/zn	12	100	23.30	19.2	14.4	11.2	6.4
M 20 x 95	k2271bk/zn	14	120	30.69	19.2	16.0	14.4	8.0
M 20 x 115	k2272bk/zn	14	120	34.50	20.8	17.6	14.4	8.0
M 24 x 120	k2281bk/zn	14	150	46.62	28.8	24.0	20.8	11.2
M 30 x 150	k2287bk/zn	17	150	91.70	43.2	33.6	27.2	17.6

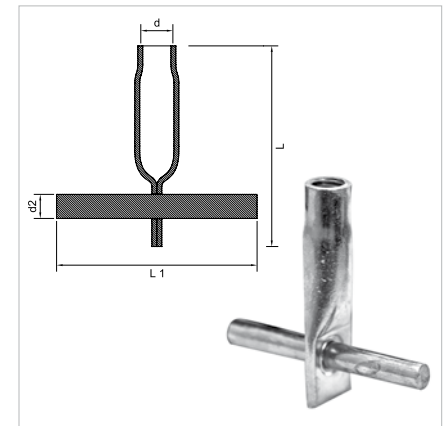

On request our fixing sockets can be given a 4-6 µm electrogalvanic coating plus yellow chromate conversion coating.

The thread is cut oversize.
The loads were determined by pullout tests carried out in unreinforced C 20/25 concrete with loads applied axially and at angles of up to 90° at government materials-testing laboratories.

Installation situation:

Tension: edge distance $c_{cr} = 1.5 \times L$

Shear: edge distance $c_{cr} = 2 \times L$

Min. element thk. $h_{min} = L + c_{mon}$

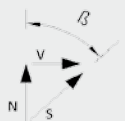

Items marked with * are fabricated from tubes with thicker walls and have a higher load-carrying capacity.

The fixing socket is used as a permanent fixture and complies with the requirements of the Construction Products Regulation (CE marking, declaration of conformity to DIN EN 1090).

For thread length (g) and embedment length (s) see List 21, steel.

Custom versions on request.
Errors and omissions excepted.
Position as of Jan 2015

Dimensions [mm]		Nailing plate type	approx. weight per 100 pieces [kg]	Permissible load ¹⁾			
Mild steel (bk) / Galvanised + chromated steel (zn)				Axial pull	Inclined pull S_{Rd}		90° pull
d x L	Order No.			N_{Rd}	$B_{Rd} \leq 30^\circ$	$B_{Rd} \leq 45^\circ$	V_{Rd}
				[kN]			
M 6 x 35	k2309bk/zn	A	2.07	2.4	1.9	1.4	0.8
M 8 x 53	k2317bk/zn	A	2.80	3.8	3.2	2.4	1.6
M 10 x 57	k2327bk/zn	A	3.70	4.6	3.7	2.7	1.6
M 10 x 57*	k2335bk/zn	A	4.47	7.2	6.4	4.8	4.0
M 12 x 55	k2339bk/zn	A	4.00	7.0	5.9	4.0	2.4
M 12 x 62*	k2349bk/zn	A	5.76	9.6	8.0	6.4	5.6
M 16 x 80	k2361bk/zn	A	10.52	20.8	17.6	14.4	12.8
M 16 x 100	k2362bk/zn	A	13.47	20.8	17.6	14.4	12.8
M 20 x 95	k2371bk/zn	B1	20.00	27.2	24.0	20.8	14.4
M 24 x 120	k2381bk/zn	B1	31.00	32.0	27.2	24.0	16.0
M 30 x 150	k2387bk/zn	B2	71.65	62.4	51.2	40.0	20.8

¹⁾ The loads given here can only be achieved when using U-bar anchorages in reinforcing steel grade B500B with the following dimensions [mm]:

U-bar anchorage B500B [mm]			
d	d_s	D_{min}	G
M 10	8	60	250
M 12	10	60	300
M 16	10	70	350
M 20	12	80	400
M 24	12	80	450
M 30	14	100	600

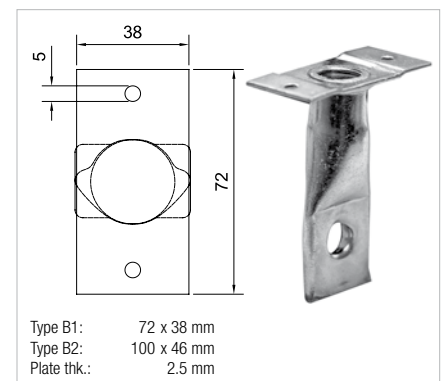
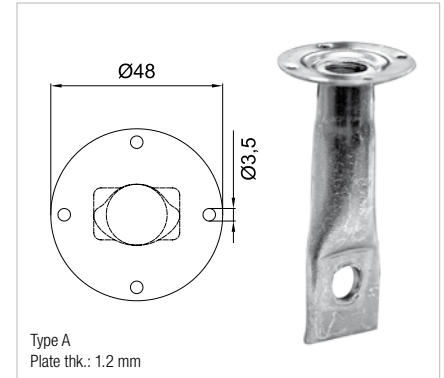
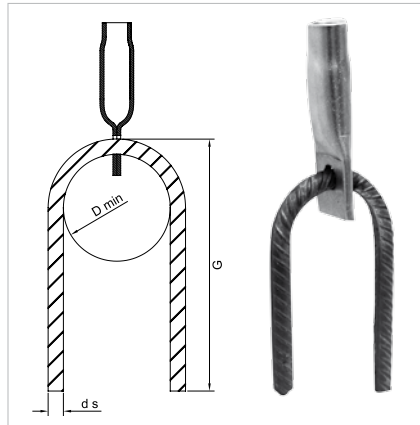

On request our fixing sockets can be given a 4-6 μ m electrogalvanic coating plus yellow chromate conversion coating.

The thread is cut oversize.
The loads were determined by pullout tests carried out in unreinforced C 20/25 concrete with loads applied axially and at angles of up to 90° at government materials-testing laboratories.

Installation situation:
Tension: edge distance $c_{cr} = 1.5 \times L$
Shear: edge distance $c_{cr} = 2 \times L$
Min. element thk. $h_{min} = L + c_{mon}$

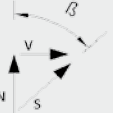

Items marked with * are fabricated from tubes with thicker walls and have a higher load-carrying capacity.

The thread is used as a permanent fixture and complies with the requirements of the Construction Products Regulation (CE marking, declaration of conformity to DIN EN 1090).

Custom versions on request.
Errors and omissions excepted.
Position as of Jan 2015

Dimensions

Load group	Dimensions [mm]				approx. weight per 100 pieces
	Mild steel (bk) / Galvanised + chromated steel (zn)				
	d x L	Order No.	g	e	[kg]
0.4	M 10 x 50	k3010bk/zn	22	10.3	3.10
0.5	M 12 x 60	k3012bk/zn	25	10.3	4.10
1.2	M 16 x 79	k3016bk/zn	27	13.3	11.10
2.0	M 20 x 99	k3020bk/zn	37	15.3	22.00
2.5	M 24 x 112	k3024bk/zn	43	17.3	30.00
3.0	M 27 x 131	k3027bk/zn	44	19.5	38.00
4.0	M 30 x 156	k3030bk/zn	56	19.5	76.60

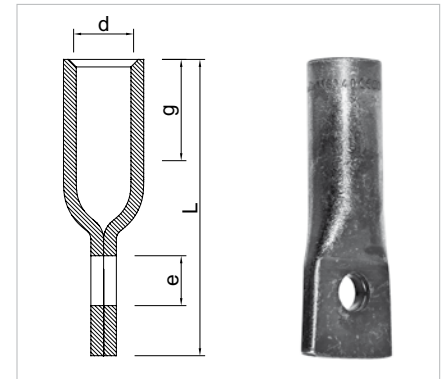

Anchorage reinforcement*

U-bar anchorage B500B [mm]			
d	d _s	G	D _{min}
M 10	8	250	60
M 12	8	300	60
M 16	10	350	70
M 20	12	400	80
M 24	14	450	100
M 27	16	500	116
M 30	16	600	130

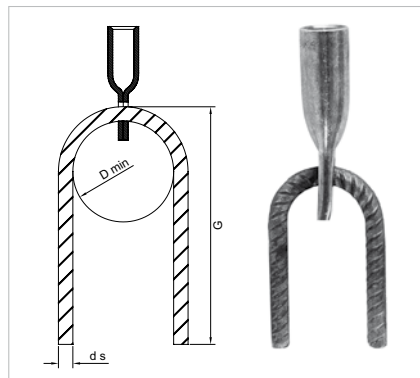

* Provided and fixed by others on site

A reinforcing bar is passed through the hole to anchor the socket. Owing to the flexible anchorage options, these sockets can be used in diverse components - walls, slabs, pipes, etc.

This product complies with the requirements of VDI/BV-BS Guideline 6205 and the European Machinery Directive 2006/42/EC.

Material:

Lifting sockets made from steel tube for precision applications to DIN EN 10305 (grade E 355+N).

On request our lifting sockets can be galvanised with a 4-6 µm zinc coating plus a yellow chromate conversion coating.

The thread is cut oversize.

All dimensions can be supplied with knuckle (Rd) thread.

This product group is also available as GS-tested sockets.

Custom versions on request.
Errors and omissions excepted.
Position as of Jan 2015

Permissible loads

Load group	Type	Typical installation situation		Permissible loads				
		Element thickness h_{cr}	Edge distance C_{cr}	Axial pull $perm F_V$	90° pull $perm F_Q$	Inclined pull $perm F_S$ $\beta \leq 45^\circ$		
				Alpha Goliath List 42	Alpha Goliath	List 42	Goliath	Alpha
	[M/Rd]	[cm]		[kN]				

Concrete strength $f_{ck} \geq 15 \text{ N/mm}^2$

0.4	10 x 50	8.0	14.0	8	3.7	4	7	8
0.5	12 x 60	8.0	14.0	11	4.1	6	8	13
1.2	16 x 79	10.0	18.0	17	6.2	13	13	16
2.0	20 x 99	12.0	25.0	30	12.0	20	21	30
2.5	24 x 112	12.0	30.0	37	12.8	25	25	31
3.0	27 x 131	16.0	35.0	48	19.7	30	31	42
4.0	30 x 156	16.0	35.0	48	20.8	40	40	44

Concrete strength $f_{ck} \geq 25 \text{ N/mm}^2$

0.4	10 x 50	8.0	14.0	9	4.8	4	7	8
0.5	12 x 60	8.0	14.0	12	5.3	6	13	16
1.2	16 x 79	10.0	18.0	18	8.0	13	16	21
2.0	20 x 99	12.0	25.0	36	15.6	20	27	35
2.5	24 x 112	12.0	30.0	40	16.6	25	31	41
3.0	27 x 131	16.0	35.0	52	25.4	30	35	47
4.0	30 x 156	16.0	35.0	52	26.8	40	41	55

Axial pull in plane of element

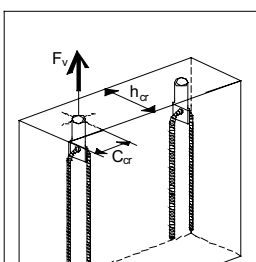

90° pull perpendicular to plane of element

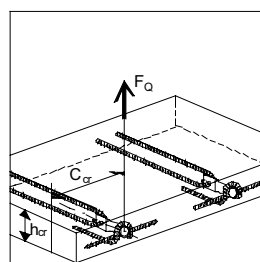

Inclined pull in plane of element

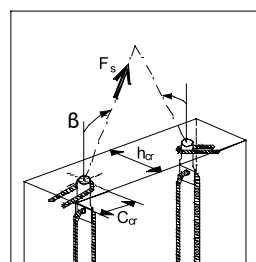

Load groups

The loading categories changed when the European Machinery Directive and VDI/BV-BS Guideline 6205 (lifting inserts/systems for PCC elements) came into force. The load group is stamped on every anchor. Given the load group and the defined typical boundary conditions in the table, it is possible to determine the permissible load of every anchor.

Level of safety

The permissible loads of lifting sockets include factors of safety $\gamma_{conc} = 2.5$ against concrete failure and $\gamma_{steel} = 3.0$ against steel failure. If the lifting sockets are not cast into concrete components under permanently quality-controlled factory conditions, then $\gamma_{conc} = 3.0$. The permissible loads must then be multiplied by the factor 0.84. The loads were determined at government materials-testing laboratories.

Element geometry

The permissible loads given in the tables are valid for the associated edge distances and element thicknesses ($S_{cr} \geq 2 \times C_{cr}$ then applies for the centre-to-centre spacing between two lifting sockets). However, these are not minimum spacings. The permissible loads might need to be increased or decreased for other mounting conditions. **Just ask us - we'd be delighted to help you.**

Minimum reinforcement

The permissible loads were determined with the sockets cast into concrete components without the structural reinforcement required. Slab-type elements require two layers of Q 188 mesh as structural reinforcement.

Anchorage reinforcement

The permissible loads are only valid in conjunction with anchorage reinforcement installed by others on site.

Converting kN to t

A body with a mass of 1.0 t has a weight of approx. 10 kN.

Additional reinforcement for inclined pull in plane of element

Additional reinforcement* B500B [mm]			
Thread [M/Rd]	Inclined pull		
	d_s	D_{min}	L
10	6	24	130
12	8	32	130
16	8	32	170
20	10	40	220
24	10	40	240
27	14	56	240
30	14	56	265

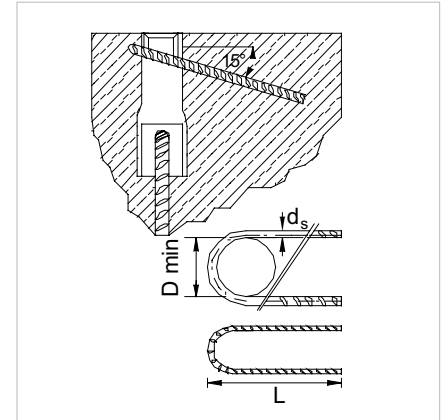

Additional reinforcement for 90° pull perpendicular to plane of element

Additional reinforcement* B500B [mm]			
Thread [M/Rd]	90° pull		
	d_s	D_{min}	L_1
10	6	24	95
12	8	32	95
16	8	32	130
20	10	40	170
24	10	40	185
27	14	56	195
30	14	56	195

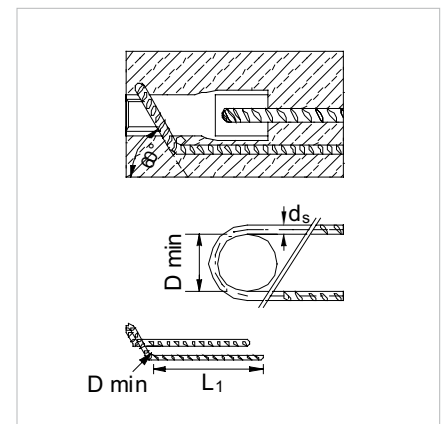

*The additional reinforcement must press against the socket.



Lifting socket

with straight bar

31

straight

Dimensions

Load group	Dimensions [mm]				approx. weight per 100 pieces
	Mild steel (bk) / Galvanised + chromated steel (zn)				
	d x L	Order No.	g	d _s	[kg]
0.5	M/Rd 12 x 200	k3112gm/r	25	8	10.30
0.8	M/Rd 14 x 230	k3114gm/r	25	10	17.10
1.2	M/Rd 16 x 270	k3116gm/r	27	12	29.40
1.6	Rd 18 x 300	k3118gr	35	14	41.30
2.0	M/Rd 20 x 350	k3120gm/r	35	14	53.50
2.5	M/Rd 24 x 400	k3124gm/r	43	16	79.40
4.0	M/Rd 30 x 500	k3130gm/r	56	20	157.30
6.3	M/Rd 36 x 650	k3136gm/r	69	25	303.10
8.0	M/Rd 42 x 850	k3142gm/r	80	28	489.20
12.5	M/Rd 52 x 900	k3152gm/r	100	32	743.50

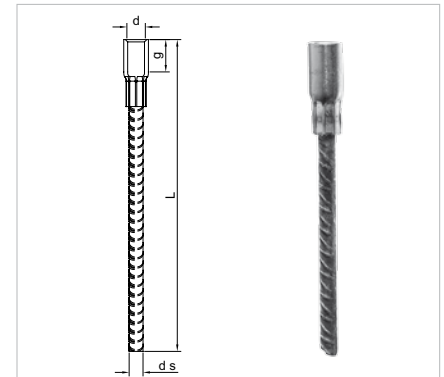

Stainless steel socket:

Also available with friction-welded stainless steel socket made from solid material for better corrosion resistance. A true stainless steel fitting.

Lifting socket with straight bar.

The socket is anchored with a reinforcing bar. Owing to the relatively long anchorage length, these sockets are particularly suitable for casting into wall-type components parallel with the plane of the wall.

Material:

Lifting sockets made from steel tube for precision applications to DIN EN 10305 (grade E 355+N). Available in electrogalvanised steel with a 4-6 µm zinc coating, mechanically zinc plated or in stainless steel.

Stainless steel according to approval Z-30.3-6 from 22 April 2014, grade A4.

Anchor bar grade B500B to DIN 488.

This product complies with the requirements of VDI/BV-BS Guideline 6205 and the European Machinery Directive 2006/42/EC.

The thread is cut oversize.

All dimensions can be supplied with knuckle (Rd) thread.

This product group is also available as GS-tested sockets.

Custom versions on request.
Errors and omissions excepted.
Position as of Jan 2015



Permissible loads

Load group	Type	Typical installation situation		Permissible loads		
		Element thickness h_{cr}	Edge distance C_{cr}	Axial pull ${}_{perm}F_V$	90° pull ${}_{perm}F_Q$	Inclined pull ${}_{perm}F_S$ $B \leq 45^\circ$
				Alpha Goliath List 42	Alpha Goliath	Alpha Goliath List 42
	[M/Rd]	[cm]		[kN]		

Concrete strength $f_{ck} \geq 15 \text{ N/mm}^2$

0.5	12 x 200	6	14	9.0	3.5	6.0
0.8	14 x 230	6	18	10.0	3.5	6.0
1.2	16 x 270	8	18	14.0	4.0	7.0
1.6	18 x 300	10	20	28.0	8.0	11.0
2.0	20 x 350	10	25	28.0	10.0	11.0
2.5	24 x 400	10	30	40.0	10.0	17.0
4.0	30 x 500	14	35	57.0	22.0	31.0
6.3	36 x 650	14	40	80.0	22.0	35.0
8.0	42 x 850	16	50	110.0	22.0	57.0
12.5	52 x 900	20	60	160.0	42.0	62.0

Concrete strength $f_{ck} \geq 25 \text{ N/mm}^2$

0.5	12 x 200	6	14	11.0	4.5	8.0
0.8	14 x 230	6	18	13.0	4.5	8.0
1.2	16 x 270	8	18	19.0	5.0	8.0
1.6	18 x 300	10	20	34.0	10.0	14.0
2.0	20 x 350	10	25	34.0	13.0	14.0
2.5	24 x 400	10	30	45.0	13.0	21.0
4.0	30 x 500	14	35	65.0	29.0	40.0
6.3	36 x 650	14	40	100.0	29.0	45.0
8.0	42 x 850	16	50	130.0	29.0	74.0
12.5	52 x 900	20	60	180.0	54.0	81.0

Axial pull in plane of element

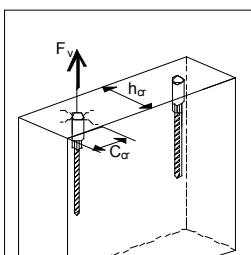

90° pull perpendicular to plane of element

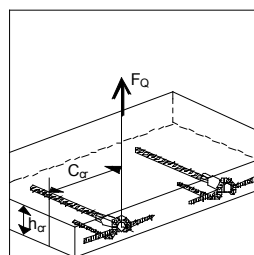

Inclined pull in plane of element

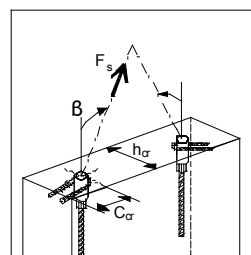

Load groups

The loading categories changed when the European Machinery Directive and VDI/BV-BS Guideline 6205 (lifting inserts/systems for PCC elements) came into force.

The load group is stamped on every anchor. Given the load group and the defined typical boundary conditions in the table, it is possible to determine the permissible load of every anchor.

Level of safety

The permissible loads of lifting sockets include factors of safety $\gamma_{conc} = 2.5$ against concrete failure and $\gamma_{steel} = 3.0$ against steel failure. If the lifting sockets are not cast into concrete components under permanently quality-controlled factory conditions, then $\gamma_{conc} = 3.0$. The permissible loads must then be multiplied by the factor 0.84. The loads were determined at government materials-testing laboratories.

Element geometry

The permissible loads given in the tables are valid for the associated edge distances and element thicknesses ($S_{cr} \geq 2 \times C_{cr}$ then applies for the centre-to-centre spacing between two lifting sockets). However, these are not minimum spacings. The permissible loads might need to be increased or decreased for other mounting conditions. **Just ask us - we'd be delighted to help you.**

Minimum reinforcement

The permissible loads were determined with the sockets cast into concrete elements without the structural reinforcement required. Slab-type elements require two layers of Q 188 mesh as structural reinforcement.

Converting kN to t

A body with a mass of 1.0 t has a weight of approx. 10 kN.

Additional reinforcement for inclined pull in plane of element

Additional reinforcement* B500B [mm]			
Thread [M/Rd]	Inclined pull		
	d_s	D_{min}	L
12	8	32	130
14	8	32	160
16	8	32	170
18	10	40	185
20	10	40	220
24	10	40	240
30	14	56	165
36	14	56	185
42	20	140	350
52	20	140	370

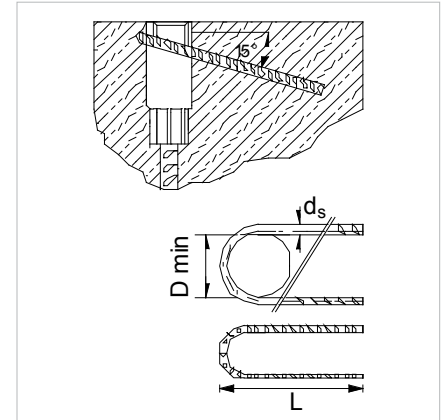

Additional reinforcement for 90° pull perpendicular to plane of element

Additional reinforcement* B500B [mm]			
Thread [M/Rd]	90° pull		
	d_s	D_{min}	L_1
12	8	32	95
14	8	32	125
16	8	32	130
18	10	40	140
20	10	40	170
24	10	40	185
30	14	56	195
36	14	56	200
42	20	140	215
52	20	140	220

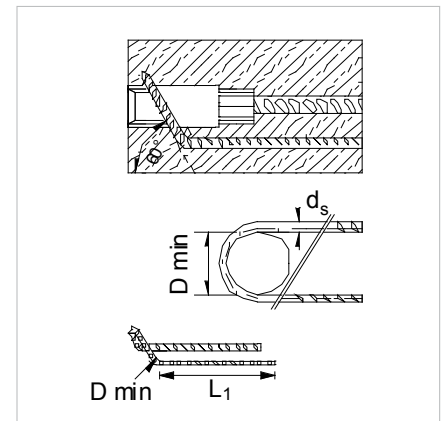

*The additional reinforcement must press against the socket.



Lifting socket

with long wavy-tail bar

31

long

Dimensions

Load group	Dimensions [mm]				approx. weight per 100 pieces [kg]
	d x L	Order No.	g	d _s	
0.5	M/Rd 12 x 300	k3112lm/r	25	8	14.60
0.8	M/Rd 14 x 310	k3114lm/r	25	10	22.60
1.2	M/Rd 16 x 320	k3116lm/r	27	12	34.80
1.6	Rd 18 x 360	k3118lr	35	14	50.90
2.0	M/Rd 20 x 400	k3120lm/r	35	14	61.90
2.5	M/Rd 24 x 450	k3124lm/r	43	16	90.40
4.0	M/Rd 30 x 600	k3130lm/r	56	20	186.90
6.3	M/Rd 36 x 750	k3136lm/r	69	25	347.10
8.0	M/Rd 42 x 850	k3142lm/r	80	28	498.90
12.5	M/Rd 52 x 900	k3152lm/r	100	32	756.10

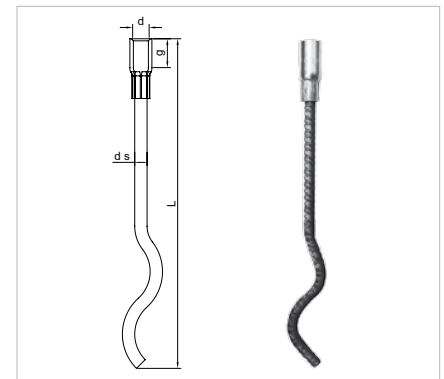

Stainless steel version:

Also available with friction-welded stainless steel socket made from solid material for better corrosion resistance. A true stainless steel fitting.

Socket with long wavy-tail bar. The socket is anchored with a reinforcing bar. Owing to the relatively long anchorage length, these sockets are particularly suitable for casting into wall-type elements parallel with the plane of the wall.

Material:

Lifting sockets made from steel tube for precision applications to DIN EN 10305 (grade E 355+N). Available in electrogalvanised steel with a 4-6 µm zinc coating, mechanically zinc plated or in stainless steel.

Stainless steel according to approval Z-30.3-6 from 22 April 2014, grade A4.

Anchor bar grade B500B to DIN 488.

This product complies with the requirements of VDI/BV-BS Guideline 6205 and the European Machinery Directive 2006/42/EC.

The thread is cut oversize.

All dimensions can be supplied with knuckle (Rd) thread.

This product group is also available as GS-tested sockets.

Custom versions on request.
Errors and omissions excepted.
Position as of Jan 2015



Permissible loads

Load group	Type	Typical installation situation		Permissible loads		
		Element thickness h_{cr}	Edge distance C_{cr}	Axial pull ${}_{perm}F_V$	90° pull ${}_{perm}F_Q$	Inclined pull ${}_{perm}F_S$ $B \leq 45^\circ$
				Alpha Goliath List 42	Alpha Goliath	Alpha Goliath List 42
	[M/Rd]	[cm]		[kN]		

Concrete strength $f_{ck} \geq 15 \text{ N/mm}^2$

0.5	12 x 300	6	14	10.0	3.5	13.0
0.8	14 x 310	6	18	11.0	3.5	14.0
1.2	16 x 320	8	18	16.0	4.0	16.0
1.6	18 x 360	10	20	28.0	8.0	18.0
2.0	20 x 400	10	25	30.0	10.0	20.0
2.5	24 x 450	10	30	40.0	10.0	23.0
4.0	30 x 600	14	35	57.0	22.0	44.0
6.3	36 x 750	14	40	90.0	22.0	49.0
8.0	42 x 850	16	50	122.0	22.0	61.0
12.5	52 x 900	20	60	180.0	42.0	75.0

Concrete strength $f_{ck} \geq 25 \text{ N/mm}^2$

0.5	12 x 300	6	14	11.0	4.5	16.0
0.8	14 x 310	6	18	14.0	4.5	18.0
1.2	16 x 320	8	18	21.0	5.0	20.0
1.6	18 x 360	10	20	34.0	10.0	24.0
2.0	20 x 400	10	25	34.0	13.0	25.0
2.5	24 x 450	10	30	45.0	13.0	28.0
4.0	30 x 600	14	35	65.0	29.0	57.0
6.3	36 x 750	14	40	100.0	29.0	65.0
8.0	42 x 850	16	50	130.0	29.0	78.0
12.5	52 x 900	20	60	180.0	54.0	98.0

Axial pull in plane of element

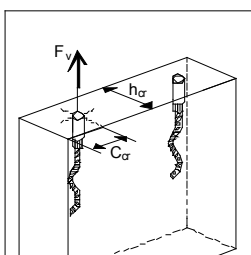

90° pull perpendicular to plane of element

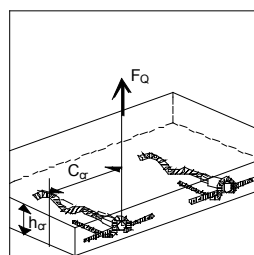

Inclined pull in plane of element

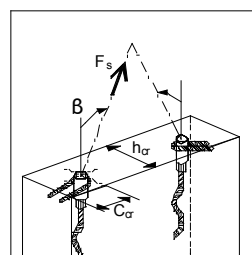

Load groups

The loading categories changed when the European Machinery Directive and VDI/BV-BS Guideline 6205 (lifting inserts/systems for PCC elements) came into force. The load group is stamped on every anchor. Given the load group and the defined typical boundary conditions in the table, it is possible to determine the permissible load of every anchor.

Level of safety

The permissible loads of lifting sockets include factors of safety $\gamma_{conc} = 2.5$ against concrete failure and $\gamma_{steel} = 3.0$ against steel failure. If the lifting sockets are not cast into concrete elements under permanently quality-controlled factory conditions, then $\gamma_{conc} = 3.0$. The permissible loads must then be multiplied by the factor 0.84. The loads were determined at government materials-testing laboratories.

Element geometry

The permissible loads given in the tables are valid for the associated edge distances and element thicknesses ($S_{cr} \geq 2 \times C_{cr}$ then applies for the centre-to-centre spacing between two lifting sockets). However, these are not minimum spacings. The permissible loads might need to be increased or decreased for other mounting conditions. **Just ask us - we'd be delighted to help you.**

Minimum reinforcement

The permissible loads were determined with the sockets cast into concrete elements without the structural reinforcement required. Slab-type elements require two layers of Q 188 mesh as structural reinforcement.

Converting kN to t

A body with a mass of 1.0 t has a weight of approx. 10 kN.

Additional reinforcement for inclined pull in plane of element

Additional reinforcement* B500B [mm]			
Thread [M/Rd]	Inclined pull		
	d_s	D_{min}	L
12	8	32	130
14	8	32	160
16	8	32	170
18	10	40	185
20	10	40	220
24	10	40	240
30	14	56	165
36	14	56	185
42	20	140	350
52	20	140	370

Additional reinforcement for 90° pull perpendicular to plane of element

Additional reinforcement* B500B [mm]			
Thread [M/Rd]	90° pull		
	d_s	D_{min}	L_1
12	8	32	95
14	8	32	125
16	8	32	130
18	10	40	140
20	10	40	170
24	10	40	185
30	14	56	195
36	14	56	200
42	20	140	215
52	20	140	220

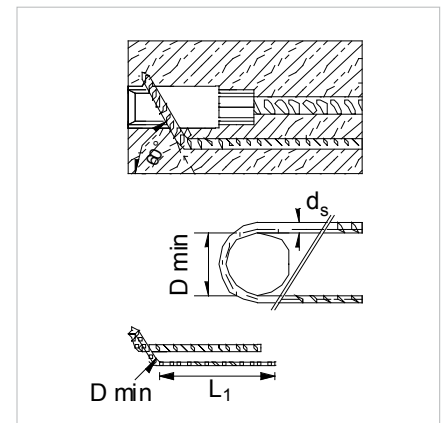
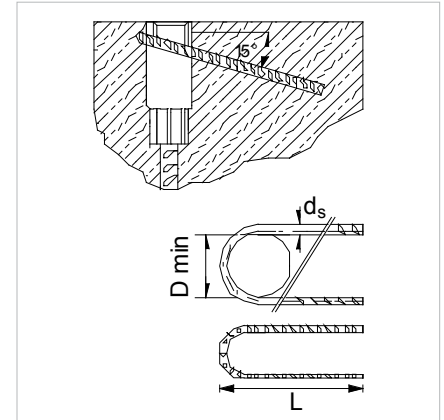

*The additional reinforcement must press against the socket.



Lifting socket

with short wavy-tail bar

31

short

Dimensions

Load group	Dimensions [mm]				approx. weight per 100 pieces [kg]
	d x L	Order No.	g	d _s	
0.5	M/Rd 12 x 150	k3112km/r	25	8	8.50
0.8	M/Rd 14 x 180	k3114km/r	25	10	14.60
1.2	M/Rd 16 x 230	k3116km/r	27	12	26.80
1.6	Rd 18 x 260	k3118kr	35	14	38.80
2.0	M/Rd 20 x 260	k3120km/r	35	14	45.00
2.5	M/Rd 24 x 300	k3124km/r	43	16	66.80
4.0	M/Rd 30 x 420	k3130km/r	56	20	142.60
6.3	M/Rd 36 x 460	k3136km/r	69	25	253.30
8.0	M/Rd 42 x 500	k3142km/r	80	28	329.70
12.5	M/Rd 52 x 550	k3152km/r	100	32	516.00

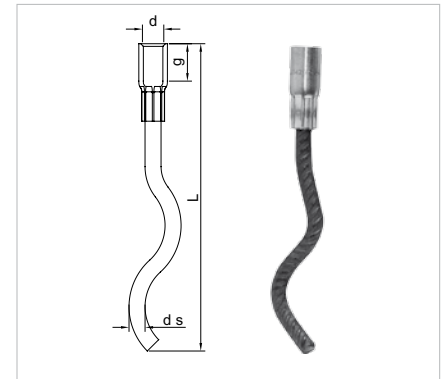

Stainless steel version:

Also available with friction-welded stainless steel socket made from solid material for better corrosion resistance. A true stainless steel fitting.

Socket with short wavy-tail bar. The socket is anchored with a reinforcing bar. Owing to the relatively short anchorage length, these sockets are particularly suitable for casting into wall-type elements perpendicular to the plane of the wall.

Material:

Lifting sockets made from steel tube for precision applications to DIN EN 10305 (grade E 355+N). Available in electrogalvanised steel with a 4-6 µm zinc coating, mechanically zinc plated or in stainless steel.

Stainless steel according to approval Z-30.3-6 from 22 April 2014, grade A4.

Anchor bar grade B500B to DIN 488.

This product complies with the requirements of VDI/BV-BS Guideline 6205 and the European Machinery Directive 2006/42/EC.

The thread is cut oversize.

All dimensions can be supplied with knuckle (Rd) thread.

This product group is also available as GS-tested sockets.

Custom versions on request.
Errors and omissions excepted.
Position as of Jan 2015



Permissible loads

Load group	Type	Typical installation situation		Permissible loads		
		Element thickness h_{cr}	Edge distance C_{cr}	Axial pull $perm F_V$	90° pull $perm F_Q$	Inclined pull $perm F_S$ $B \leq 45^\circ$
				Alpha Goliath List 42	Alpha Goliath	Alpha Goliath List 42
	[M/Rd]	[cm]		[kN]		

Concrete strength $f_{ck} \geq 15 \text{ N/mm}^2$

0.5	12 x 150	6	14	5.0	2.0	6.0
0.8	14 x 180	6	18	8.0	2.4	6.0
1.2	16 x 230	8	18	14.0	7.4	7.0
1.6	18 x 260	10	20	20.0	9.0	10.0
2.0	20 x 260	10	25	20.0	9.0	11.0
2.5	24 x 300	10	30	23.0	9.0	17.0
4.0	30 x 420	14	35	36.0	20.0	31.0
6.3	36 x 460	14	40	59.0	20.0	35.0
8.0	42 x 500	16	50	70.0	20.0	57.0
12.5	52 x 550	20	60	100.0	38.0	62.0

Concrete strength $f_{ck} \geq 25 \text{ N/mm}^2$

0.5	12 x 150	6	14	7.0	2.6	8.0
0.8	14 x 180	6	18	11.0	3.1	8.0
1.2	16 x 230	8	18	18.0	9.6	8.0
1.6	18 x 260	10	20	26.0	11.6	14.0
2.0	20 x 260	10	25	26.0	11.6	14.0
2.5	24 x 300	10	30	30.0	11.6	21.0
4.0	30 x 420	14	35	47.0	25.8	40.0
6.3	36 x 460	14	40	76.0	25.8	45.0
8.0	42 x 500	16	50	90.0	25.8	74.0
12.5	52 x 550	20	60	130.0	49.0	81.0

Axial pull in plane of element

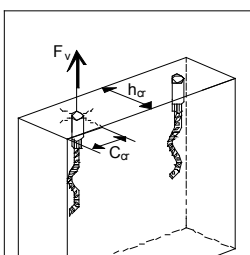

90° pull perpendicular to plane of element

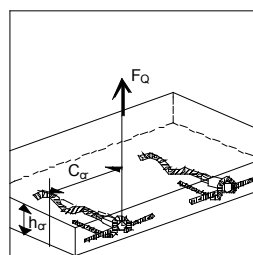

Inclined pull in plane of element

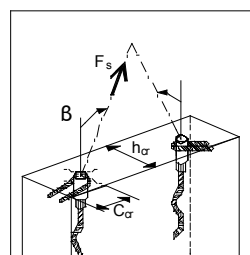

Load groups

The loading categories changed when the European Machinery Directive and VDI/BV-BS Guideline 6205 (lifting inserts/systems for PCC elements) came into force.

The load group is stamped on every anchor. Given the load group and the defined typical boundary conditions in the table, it is possible to determine the permissible load of every anchor.

Level of safety

The permissible loads of lifting sockets include factors of safety $\gamma_{conc} = 2.5$ against concrete failure and $\gamma_{steel} = 3.0$ against steel failure. If the lifting sockets are not cast into concrete elements under permanently quality-controlled factory conditions, then $\gamma_{conc} = 3.0$. The permissible loads must then be multiplied by the factor 0.84.

The loads were determined at government materials-testing laboratories.

Element geometry

The permissible loads given in the tables are valid for the associated edge distances and element thicknesses ($S_{cr} \geq 2 \times C_{cr}$ then applies for the centre-to-centre spacing between two lifting sockets). However, these are not minimum spacings.

The permissible loads might need to be increased or decreased for other mounting conditions.

Just ask us - we'd be delighted to help you.

Minimum reinforcement

The permissible loads were determined with the sockets cast into concrete elements without the structural reinforcement required. Slab-type elements require two layers of Q 188 mesh as structural reinforcement.

Converting kN to t

A body with a mass of 1.0 t has a weight of approx. 10 kN.

Additional reinforcement for inclined pull in plane of element

Additional reinforcement* B500B [mm]			
Thread [M/Rd]	Inclined pull		
	d_s	D_{min}	L
12	8	32	130
14	8	32	160
16	8	32	170
18	10	40	185
20	10	40	220
24	10	40	240
30	14	56	165
36	14	56	185
42	20	140	350
52	20	140	370

Additional reinforcement for 90° pull perpendicular to plane of element

Additional reinforcement* B500B [mm]			
Thread [M/Rd]	90° pull		
	d_s	D_{min}	L_1
12	8	32	95
14	8	32	125
16	8	32	130
18	10	40	140
20	10	40	170
24	10	40	185
30	14	56	195
36	14	56	200
42	20	140	215
52	20	140	220

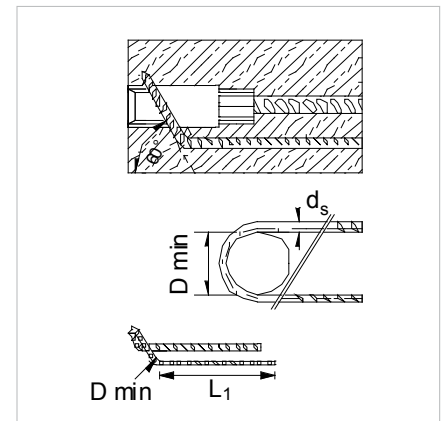
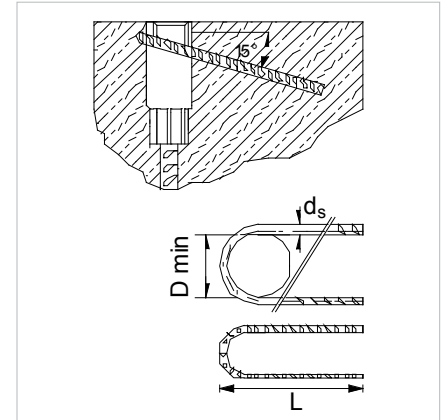

*The additional reinforcement must press against the socket.

Dimensions

Load group	Dimensions [mm]				approx. weight per 100 pieces [kg]
	Mild steel (bk) / Galvanised + chromated steel (zn)				
	d x L	Order No.	g	e	
0.5	Rd 12 x 40	k3212bk/zn	22	8	2.80
0.8	Rd 14 x 47	k3214bk/zn	25	10	4.17
1.2	Rd 16 x 54	k3216bk/zn	27	13	7.21
1.6	Rd 18 x 65	k3218bk/zn	34	13	9.00
2.0	Rd 20 x 69	k3220bk/zn	35	15	14.53
2.5	Rd 24 x 78	k3224bk/zn	43	18	20.00
4.0	Rd 30 x 103	k3230bk/zn	56	22	48.00
6.3	Rd 36 x 125	k3236bk/zn	68	27	74.42
8.0	Rd 42 x 145	k3242bk/zn	80	32	106.00
12.5	Rd 52 x 195	k3252bk/zn	97	40	223.00

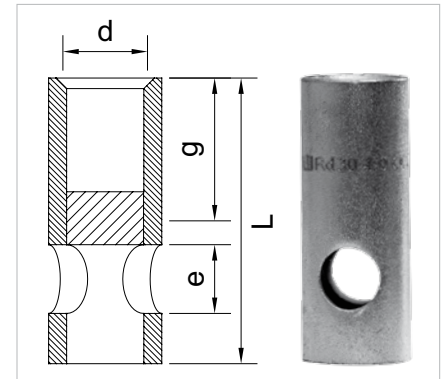

Anchorage reinforcement

U-bar anchorage B500B [mm]			
d	d _s	G	D _{min}
Rd 12	6	300	60
Rd 14	8	300	70
Rd 16	10	350	70
Rd 18	10	350	70
Rd 20	12	400	80
Rd 24	14	450	100
Rd 30	16	600	130
Rd 36	20	600	150
Rd 42	25	650	200
Rd 52	28	900	300

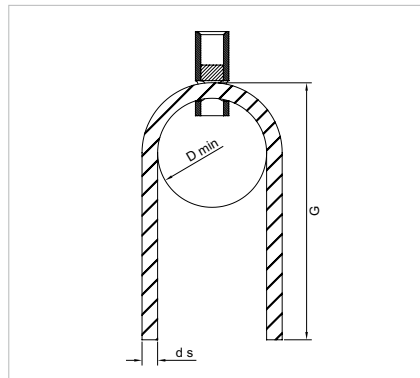

Lifting socket made from tubular material, with cross-hole.

A reinforcing bar is passed through the hole to anchor the socket. These sockets can be used in a diverse concrete elements due to the flexible arrangements possible with the anchorage bar.

Material:

Lifting sockets made from steel tube for precision applications to DIN EN 10305 (grade E 355+N). A plastic plug in the tube prevents concrete entering the threaded part from below.

On request our lifting sockets can be galvanised with a 4-6 µm zinc coating plus a yellow chromate conversion coating.

The thread is cut oversize.

All dimensions can be supplied with metric thread (M).

This product complies with the requirements of VDI/BV-BS Guideline 6205 and the European Machinery Directive 2006/42/EC.

Custom versions on request.
Errors and omissions excepted.
Position as of Jan 2015

Permissible loads

Load group	Type	Typical installation situation		Permissible loads				
		Element thickness h_{cr}	Edge distance C_{cr}	Axial pull $perm F_V$	90° pull $perm F_Q$	Inclined pull $perm F_S$ $\beta \leq 45^\circ$		
				Alpha Goliath List 42	Alpha Goliath	List 42	Goliath	Alpha
	[M/Rd]	[cm]		[kN]				

Concrete strength $f_{ck} \geq 15 \text{ N/mm}^2$								
0.5	12 x 40	8.0	14.0	11	4.1	6	8	13
0.8	14 x 47	8.0	18.0	12	5.3	8	10	14
1.2	16 x 54	10.0	18.0	17	6.2	13	13	16
1.6	18 x 65	12.0	25.0	18	7.0	14	14	17
2.0	20 x 69	12.0	25.0	30	12.0	20	21	30
2.5	24 x 78	12.0	30.0	37	12.8	25	25	31
4.0	30 x 103	16.0	35.0	48	20.8	40	40	44
6.3	36 x 125	16.0	40.0	63	20.8	63	63	63
8.0	42 x 145	20.0	50.0	80	20.8	80	80	80
12.5	52 x 195	20.0	60.0	125	35.0	125	125	125

Concrete strength $f_{ck} \geq 25 \text{ N/mm}^2$								
0.5	12 x 40	8.0	14.0	12	5.3	6	13	16
0.8	14 x 47	8.0	18.0	12	6.8	8	14	18
1.2	16 x 54	10.0	18.0	18	8.0	13	16	21
1.6	18 x 65	12.0	25.0	19	9.0	14	17	22
2.0	20 x 69	12.0	25.0	36	15.6	20	27	35
2.5	24 x 78	12.0	30.0	40	16.6	25	31	41
4.0	30 x 103	16.0	35.0	52	26.8	40	41	55
6.3	36 x 125	16.0	40.0	76	26.8	63	63	63
8.0	42 x 145	20.0	50.0	102	26.8	80	80	80
12.5	52 x 195	20.0	60.0	140	45.0	125	125	125

Axial pull in plane of element

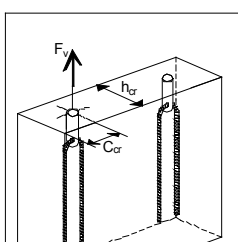

90° pull perpendicular to plane of element

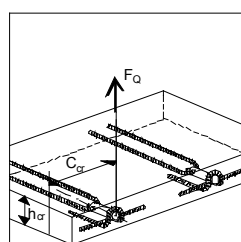

Inclined pull in plane of element

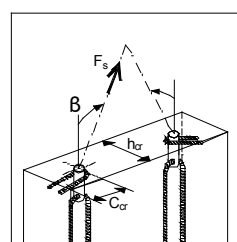

Load groups

The loading categories changed when the European Machinery Directive and VDI/BV-BS Guideline 6205 (lifting inserts/systems for PCC elements) came into force.

The load group is stamped on every anchor. Given the load group and the defined typical boundary conditions in the table, it is possible to determine the permissible load of every anchor.

Level of safety

The permissible loads of lifting sockets include factors of safety $\gamma_{conc} = 2.5$ against concrete failure and $\gamma_{steel} = 3.0$ against steel failure. If the lifting sockets are not cast into concrete components under permanently quality-controlled factory conditions, then $\gamma_{conc} = 3.0$. The permissible loads must then be multiplied by the factor 0.84.

The loads were determined at government materials-testing laboratories.

Element geometry

The permissible loads given in the tables are valid for the associated edge distances and element thicknesses ($S_{cr} \geq 2 \times C_{cr}$ then applies for the centre-to-centre spacing between two lifting sockets). However, these are not minimum spacings.

The permissible loads might need to be increased or decreased for other mounting conditions.

Just ask us - we'd be delighted to help you.

Minimum reinforcement

The permissible loads were determined with the sockets cast into concrete components without the structural reinforcement required. Slab-type components require two layers of Q 188 mesh as structural reinforcement.

Anchorage reinforcement

The permissible loads are only valid in conjunction with anchorage reinforcement installed by others on site.

Converting kN to t

A body with a mass of 1.0 t has a weight of approx. 10 kN.

Additional reinforcement for inclined pull in plane of element

Additional reinforcement* B500B [mm]			
Thread [Rd]	Inclined pull		
	d_s	D_{min}	L
12	8	32	130
14	8	32	160
16	8	32	170
18	10	40	185
20	10	40	220
24	10	40	240
30	14	56	265
36	14	56	285
42	20	140	350
52	20	140	370

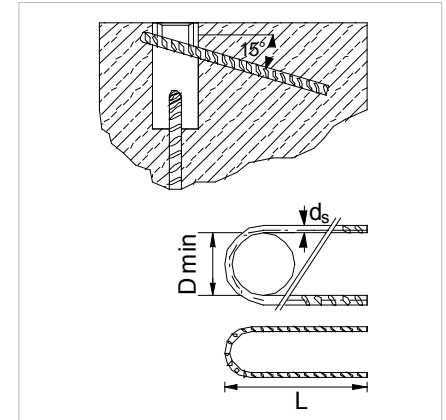

Additional reinforcement for 90° pull perpendicular to plane of element

Additional reinforcement* B500B [mm]			
Thread [Rd]	90° pull		
	d_s	D_{min}	L_1
12	8	24	95
14	8	24	125
16	8	32	130
18	10	32	140
20	10	40	170
24	10	48	185
30	14	48	195
36	14	64	200
42	20	140	215
52	20	140	220

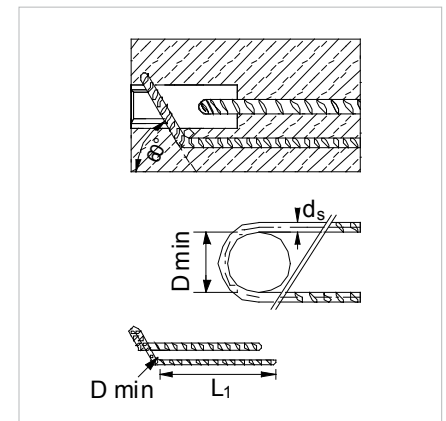

*The additional reinforcement must press against the socket.



Dimensions

Load group	Dimensions [mm]						approx. weight per 100 pieces [kg]
	Mild steel (bk) / Galvanised + chromated steel (zn) / Stainless steel (va)						
			Steel		Stainless steel		
	d x L	Order No.	g	e	g	e	
0.4	M 10 x 42	k3310bk/zn/va	21	9	21	9	4.60
0.5	M 12 x 49	k3312bk/zn/va	23	11	23	11	6.00
1.2	M 16 x 57	k3316bk/zn/va	26	14	26	14	13.42
2.0	M 20 x 68	k3320bk/zn/va	33	16	33	16	25.00
2.5	M 24 x 80	k3324bk/zn/va	42	18	42	18	34.50
4.0	M 30 x 103	k3330bk/zn/va	54	22	54	22	66.30

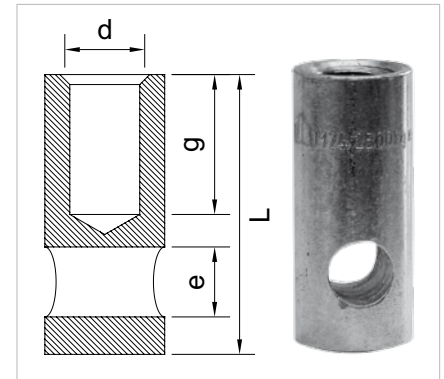

Anchorage reinforcement

U-bar anchorage B500B [mm]			
d	d _s	G	D _{min}
M 10	6	250	60
M 12	8	300	60
M 16	10	350	70
M 20	12	400	80
M 24	14	450	100
M 30	16	600	135

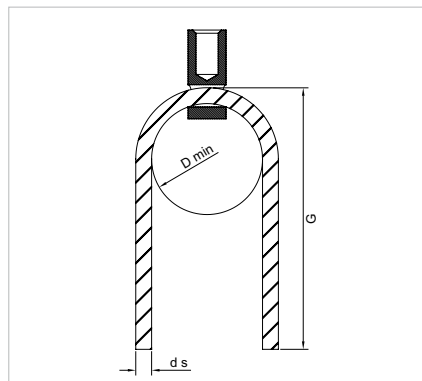

Lifting socket made from solid material, with cross-hole.

A reinforcing bar is passed through the hole to anchor the socket. These sockets can be used in a diverse concrete elements due to the flexible arrangements possible with the anchorage bar.

Material:

Fixing socket made from round steel bar to DIN EN 10305 (grade E 355+N). Stainless steel according to approval Z-30.3-6 from 22 April 2014. A plastic plug in the tube prevents concrete entering the threaded part from below.

On request our lifting sockets can be galvanised with a 4-6 µm zinc coating plus a yellow chromate conversion coating.

The thread is cut oversize.

All dimensions can be supplied with knuckle (Rd) thread.

This product complies with the requirements of VDI/BV-BS Guideline 6205 and the European Machinery Directive 2006/42/EC.

Custom versions on request. Errors and omissions excepted. Position as of Jan 2015

Permissible loads

Load group	Type	Typical installation situation		Permissible loads				
		Element thickness h_{cr}	Edge distance C_{cr}	Axial pull $perm F_V$	90° pull $perm F_Q$	Inclined pull $perm F_S$ $\beta \leq 45^\circ$		
				Alpha Goliath List 42	Alpha Goliath	List 42	Goliath	Alpha
	[M/Rd]	[cm]		[kN]				

Concrete strength $f_{ck} \geq 15 \text{ N/mm}^2$

0.4	10 x 42	8.0	14.0	8	3.7	4	7	8
0.5	12 x 49	8.0	14.0	11	4.1	6	8	13
1.2	16 x 57	10.0	18.0	17	6.2	13	13	16
2.0	20 x 68	12.0	25.0	30	12.0	20	21	30
2.5	24 x 80	12.0	30.0	37	12.8	25	25	31
4.0	30 x 103	16.0	35.0	48	20.8	40	40	44

Concrete strength $f_{ck} \geq 25 \text{ N/mm}^2$

0.4	10 x 42	8.0	14.0	9	4.8	4	7	8
0.5	12 x 49	8.0	14.0	12	5.3	6	13	16
1.2	16 x 57	10.0	18.0	18	8.0	13	16	21
2.0	20 x 68	12.0	25.0	36	15.6	20	27	35
2.5	24 x 80	12.0	30.0	40	16.6	25	31	41
4.0	30 x 103	16.0	35.0	52	26.8	40	41	55

Axial pull in plane of element

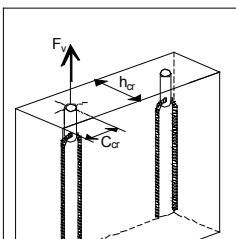

90° pull perpendicular to plane of element

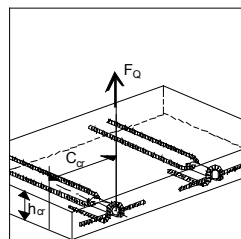

Inclined pull in plane of element

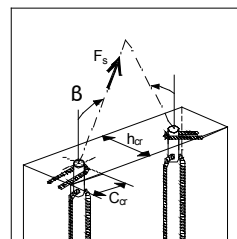

Load groups

The loading categories changed when the European Machinery Directive and VDI/BV-BS Guideline 6205 (lifting inserts/systems for PCC elements) came into force.

The load group is stamped on every anchor. Given the load group and the defined typical boundary conditions in the table, it is possible to determine the permissible load of every anchor.

Level of safety

The permissible loads of lifting sockets include a factor of safety $\gamma_{conc} = 2.5$ against concrete failure and $\gamma_{steel} = 3.0$ against steel failure. If the lifting sockets are not cast into concrete components under permanently quality-controlled factory conditions, then $\gamma_{conc} = 3.0$. The permissible loads must then be multiplied by the factor 0.84. The loads were determined at government materials-testing laboratories.

Element geometry

The permissible loads given in the tables are valid for the associated edge distances and element thicknesses ($S_{cr} \geq 2 \times C_{cr}$ then applies for the centre-to-centre spacing between two lifting sockets). However, these are not minimum spacings. The permissible loads might need to be increased or decreased for other mounting conditions. Just ask us - we'd be delighted to help you.

Minimum reinforcement

The permissible loads were determined with the sockets cast into concrete components without the structural reinforcement required. Slab-type components require two layers of Q 188 mesh as structural reinforcement.

Anchorage reinforcement

The permissible loads are only valid in conjunction with anchorage reinforcement installed by others on site.

Converting kN to t

A body with a mass of 1.0 t has a weight of approx. 10 kN.

Custom versions on request.
Errors and omissions excepted.
Position as of Jan 2015

Additional reinforcement for inclined pull in plane of element

Additional reinforcement* B500B [mm]			
Thread [Rd]	Inclined pull		
	d_s	D_{min}	L
10	6	24	130
12	8	32	130
16	8	32	170
20	10	40	220
24	10	40	240
30	14	56	265

Additional reinforcement for 90° pull perpendicular to plane of element

Additional reinforcement* B500B [mm]			
Thread [Rd]	90° pull		
	d_s	D_{min}	L_1
10	6	24	95
12	8	24	95
16	8	32	130
20	10	40	170
24	10	40	185
30	14	56	195

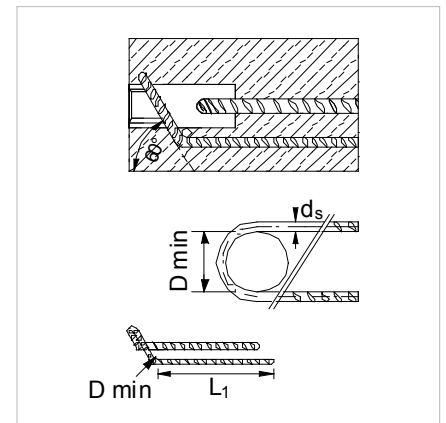
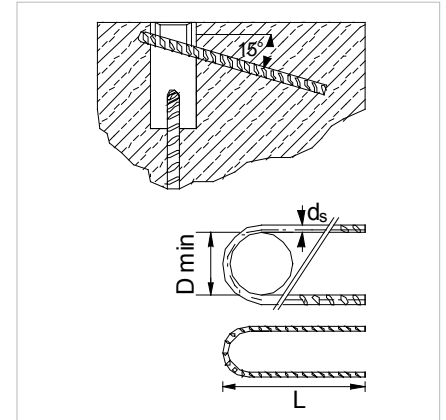

*The additional reinforcement must press against the socket.



Lifting socket

with welded end plate
Flat steel anchor

35

Dimensions

Load group	Dimensions [mm]		Mild steel (bk) / Galvanised + chromated steel (zn)	approx. weight per 100 pieces	Stainless steel A4	approx. weight per 100 pieces
	d x L	g				
with metric thread						
0.5	M 12 x 30	22	k3512mbk/zn	4.44	k3512mva	4.00
1.2	M 16 x 35	27	k3516mbk/zn	9.22	k3516mva	9.00
2.0	M 20 x 47	35	k3520mbk/zn	25.90	k3520mva	24.50
2.5	M 24 x 54	43	k3524mbk/zn	34.00	k3524mva	33.00
4.0	M 30 x 72	56	k3530mbk/zn	75.30	k3530mva	37.00
6.3	M 36 x 84	68	k3536mbk/zn	107.00	k3536mva	107.00
8.0	M 42 x 100	80	k3542mbk/zn	176.00	k3542mva	176.00
12.5	M 52 x 120	100	k3552mbk/zn	260.00	k3552mva	260.00

with knuckle thread						
0.5	Rd 12 x 30	22	k3512rbk/zn	4.44	k3512rva	4.00
1.2	Rd 16 x 35	27	k3516rbk/zn	9.22	k3516rva	9.00
2.0	Rd 20 x 47	35	k3520rbk/zn	25.90	k3520rva	24.50
2.5	Rd 24 x 54	43	k3524rbk/zn	34.00	k3524rva	33.00
4.0	Rd 30 x 72	56	k3530rbk/zn	75.30	k3530rva	37.00
6.3	Rd 36 x 84	68	k3536rbk/zn	107.00	k3536rva	107.00
8.0	Rd 42 x 100	80	k3542rbk/zn	176.00	k3542rva	176.00
12.5	Rd 52 x 120	100	k3552rbk/zn	260.00	k3552rva	260.00

End plate dimensions [mm]			
d	a	b	t
M/Rd 12	35	35	3
M/Rd 16	50	35	3
M/Rd 20	60	60	5
M/Rd 24	80	60	5
M/Rd 30	100	80	6
M/Rd 36	130	100	6
M/Rd 42	130	130	8
M/Rd 52	150	130	8

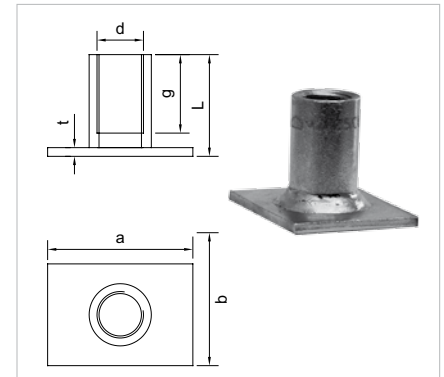

Lifting socket with end plate.
Owing to its small depth, this socket is particularly suitable for casting into slab-type elements perpendicular to the plane of the slab.

Material:
Lifting socket made from steel tube for precision applications to DIN EN 10305, grade E 355+N, welded to steel flat of grade S235JO. Stainless steel according to approval Z-30.3-6 from 22 April 2014, grade A4.

On request our lifting sockets can be galvanised with a 4-6 µm zinc coating plus a yellow chromate conversion coating.

The thread is cut oversize.

This product complies with the requirements of VDI/BV-BS Guideline 6205 and the European Machinery Directive 2006/42/EC.

Custom versions on request.
Errors and omissions excepted.
Position as of Jan 2015



Permissible loads

Load group	Type	Typical installation situation		Permissible loads
		Element thickness h_{cr}	Edge distance c_{cr}	
	[M/Rd]	[cm]		[kN]

Concrete strength $f_{ck} \geq 15 \text{ N/mm}^2$				
0.5	12 x 30	8	18	5.0
1.2	16 x 35	9	25	12.0
2.0	20 x 47	11	30	20.0
2.5	24 x 54	12.5	40	25.0
4.0	30 x 72	15	50	40.0
6.3	36 x 84	16.5	65	63.0
8.0	42 x 100	18	65	80.0
12.5	52 x 120	21.5	75	125.0

Concrete strength $f_{ck} \geq 25 \text{ N/mm}^2$				
0.5	12 x 30	8	18	6.5
1.2	16 x 35	9	25	15.5
2.0	20 x 47	11	30	25.8
2.5	24 x 54	12.5	40	32.3
4.0	30 x 72	15	50	51.6
6.3	36 x 84	16.5	65	81.3
8.0	42 x 100	18	65	103.3
12.5	52 x 120	21.5	75	161.4

Load groups

The loading categories changed when the European Machinery Directive and VDI/BV-BS Guideline 6205 (lifting inserts/systems for PCC elements) came into force.

The load group is stamped on every anchor. Given the load group and the defined typical boundary conditions in the table, it is possible to determine the permissible load of every anchor.

Level of safety

The permissible loads of lifting sockets include factors of safety $\gamma_{conc} = 2.5$ against concrete failure and $\gamma_{steel} = 3.0$ against steel failure. If the lifting sockets are not cast into concrete elements under permanently quality-controlled factory conditions, then $\gamma_{conc} = 3.0$. The permissible loads must then be multiplied by the factor 0.84.

The loads were determined at government materials-testing laboratories.

Element geometry

The permissible loads given in the tables are valid for the associated edge distances and element thicknesses ($s_{cr} \geq 2 \times c_{cr}$ then applies for the centre-to-centre spacing between two lifting sockets). However, these are not minimum spacings. The permissible loads might need to be increased or decreased for other mounting conditions. **Just ask us - we'd be delighted to help you.**

Converting kN to t

A body with a mass of 1.0 t has a weight of approx. 10 kN.

Permissible shear forces on request.

Axial pull perpendicular to plane of element

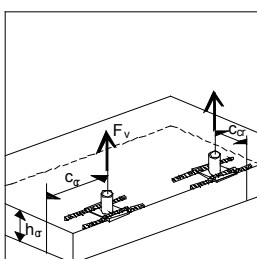

Inclined pull in plane of element

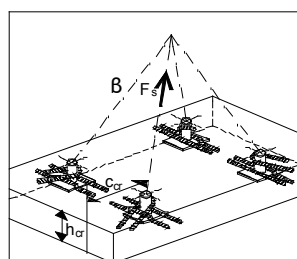

Additional reinforcement for axial pull in plane of element

Thread [M/Rd]	Minimum reinforcement	Additional reinforcement*, B500B, axial pull [mm]			
		$n \times d_s$	L_s	L_o	L_{sum}
12	Q188 A	2 x 6	60	60	250
14	Q188 A	2 x 8	70	60	360
16	Q188 A	2 x 8	70	90	420
20	Q188 A	4 x 10	80	90	640
24	Q188 A	4 x 10	100	90	640
30	Q257 A	4 x 12	110	110	830
36	Q335 A	4 x 14	120	140	1140
42	Q424 A	4 x 16	120	140	1250
52	Q524 A	4 x 20	150	160	1530

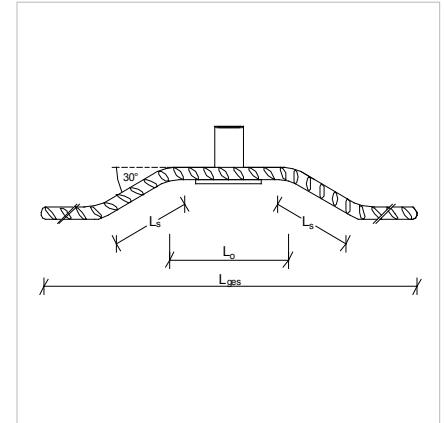

Additional reinforcement for inclined pull in plane of element

Thread [Rd]	Additional reinforcement*, B500B, inclined pull [mm]		
	d_s	D_{min}	L
12	8	32	130
14	8	32	160
16	8	32	170
20	10	40	220
24	10	40	240
30	14	56	265
36	14	56	285
42	20	140	350
52	20	140	370

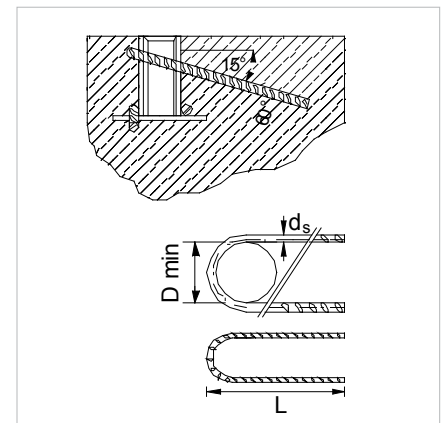

*The additional reinforcement must press against the socket.

Axial pull without additional reinforcement is possible by reducing the permissible loads. (Just ask us - we'd be delighted to help you.)



Cast-in lifting loop

made from endless crimped wire rope

36

Dimensions

Load group	Tag	with plastic strap	with steel strap	L1	Embedment depth L2	Rope Ø	approx. weight per 100 pieces
	Colour	Order No.	Order No.				
0.8	white	k3608	k3608st	200	140	6	8.00
1.2	red	k3612	k3612st	220	160	7	11.00
1.6	pink	k3616	k3616st	240	170	8	15.00
2.0	light green	k3620	k3620st	270	190	9	25.00
2.5	black	k3625	k3625st	300	220	10	28.50
4.0	dark green	k3640	k3640st	350	250	12	50.00
5.2	ochre	k3652	k3652st	370	270	14	80.00
6.3	dark blue	k3663	k3663st	400	290	16	100.00
8.0	light grey	k3680	k3680st	470	330	18	150.00
10.0	bordeaux	k36100	k36100st	520	370	20	190.00
12.5	pale yellow	k36125	k36125st	570	420	22	280.00
16.0	violet	k36160	k36160st	650	480	26	450.00
20.0	grey	k36200	k36200st	730	550	28	570.00
25.0	brown	k36250	k36250st	830	630	32	820.00

Dimensions for load groups > 25.0 to 99.0 available on request.

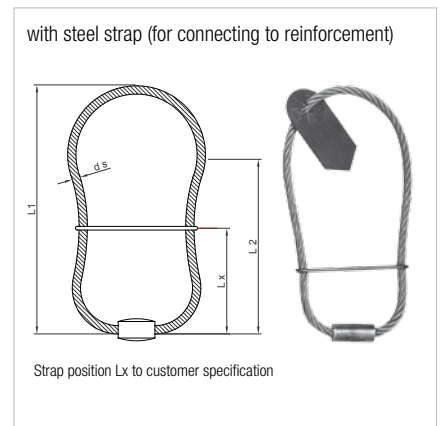
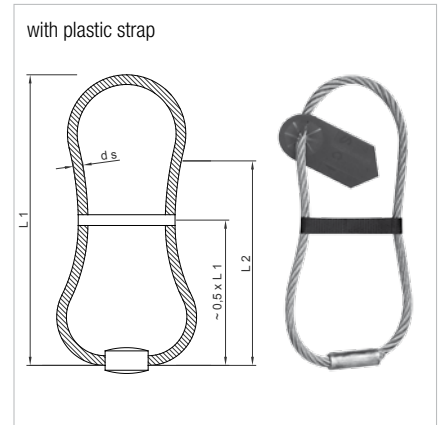

Cast-in lifting loop

made from endless crimped polypropylene rope

36

Dimensions

Load group	Order No.	Rope Ø	h	approx. weight per 100 pieces
		[mm]		
0.150	s3601	6	200	2.00
0.250	s3602	8	220	3.00
0.360	s3606	10	235	5.00
0.500	s3603	12	255	8.00
0.875	s3604	14	280	10.00
1.000	s3605	16	330	13.00



Arrangement of reinforcement

Load group	Protruding installation		Minimum reinforcement
	B [cm]	T [cm]	
			B500A
0.8	45	30	Q188 A
1.2	50	35	
1.6	55	35	
2.0	65	45	
2.5	70	50	
4.0	80	55	
5.2	85	55	Q257 A
6.3	95	60	
8.0	105	70	
10.0	120	80	
12.5	130	90	Q335 A
16.0	150	100	
20.0	170	115	
25.0	195	130	

Reinforcement

The reinforcement must constitute a framework within the element and must carry the loads transferred from the lifting loop.

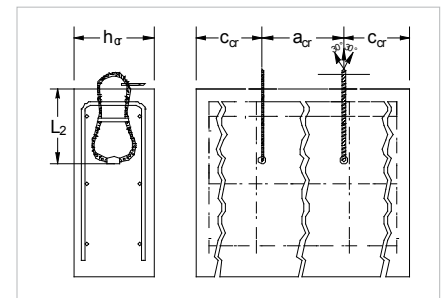
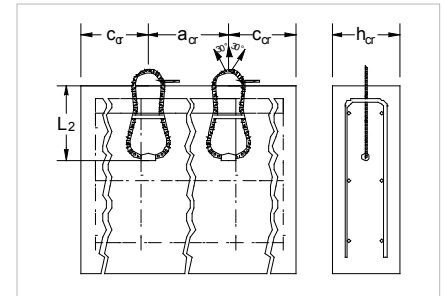
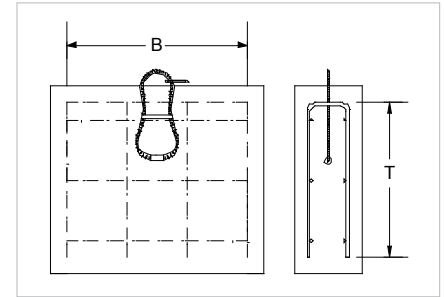

Typical installation situation

Load group	Min. centre-to-centre spacing	Min. edge distance	Embedment depth	Min. element thickness h_{cr}			
				Fitted parallel with element surface		Fitted perpendicular to element surface	
	a_{cr}	c_{cr}	L_2	C 12/15	C 20/25	C 12/15	C 20/25
[cm]							
0.8	55	27	14	7	5	13.5	13.5
1.2	62	31	16	9	6	14	14
1.6	70	35	17	12	8	17	17
2.0	85	46	19	15	10	18	18
2.5	90	45	22	16	11	18	18
4.0	100	50	25	22	15	22	22
5.2	105	53	27	29	20	30	22
6.3	115	57	29	32	22	35	28
8.0	130	65	33	40	28	40	28
10.0	145	73	37	44	31	44	31
12.5	160	80	42	56	39	55	40
16.0	185	93	48	62	43	62	43
20.0	210	105	55	68	48	68	48
25.0	240	120	63	75	53	75	53

Rope wear

The loop may not be used if there is any sign of kinks, broken strands, crushing, corrosion or birdcaging (see DIN EN 13414-2).

Loading direction

The loop may only be used for an inclined pull up to max. 30° in the plane of the element. Loading perpendicular to the plane of the element (90° pull) is not permitted.

Lifting gear

The radius of the crane hook should be at least equal to the curvature of the lifting loop in order to avoid crushing of the rope.

Corrosion

Lifting loops must not be used in concrete elements with a high risk of corrosion, e.g. permanently damp outer areas or areas with a high chloride load, due to the potential of aluminium corrosion and the concrete spalling associated with that.

Custom versions on request.

Errors and omissions excepted.

Position as of Jan 2015



Rebar coupler

socket bar (female part)

37

F

D ₁ x L	Order No.	Dimensions [mm]			approx. weight per 100 pcs.
		∅ d _s	L _{bmin} / L _{bx}	L ₁	
[mm]					[kg]
M 16 x 450	k37160450fbk	12	100/140	27	48
M 16 x 600	k37160600fbk	12	100/140	27	60
M 20 x 550	k37200550fbk	16	125/180	33	98
M 20 x 700	k37200700fbk	16	125/180	33	122
M 20 x 850	k37200850fbk	16	125/180	33	144
M 24 x 700	k37240700fbk	20	140/210	38.5	198
M 30 x 1060	k37301060fbk	25	190/275	43	430
M 42 x 1400	k37421400fbk	32	210/325	65	985
M 48 x 1600	k37481600fbk	40	230/370	52	1740

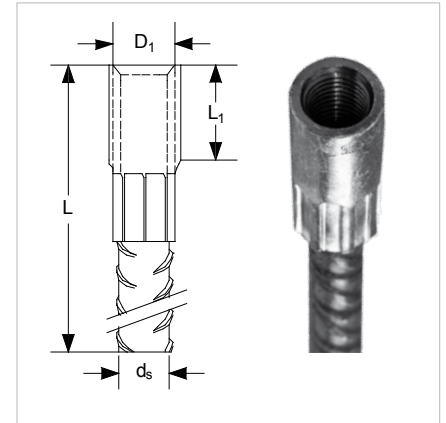

Rebar coupler

spigot bar (male part)

37

M

D ₁ x L	Order No.	Dimensions [mm]			approx. weight per 100 pcs.	M
		∅ d _s	L _{bmin} / L _{bx}	L ₁		
[mm]					[kg]	[Nm]
M 16 x 375	k37160375mbk	12	85/130	30	34	60
M 16 x 575	k37160575mbk	12	85/130	30	50	60
M 20 x 520	k37200520mbk	16	112/170	40	82	80
M 20 x 775	k37200775mbk	16	112/170	40	120	80
M 24 x 665	k37240665mbk	20	137/210	46	170	100
M 24 x 975	k37240975mbk	20	137/210	46	235	100
M 30 x 1000	k37301000mbk	25	160/250	50	386	125
M 42 x 1400	k37421400mbk	32	210/325	70	901	160
M 48 x 1700	k37481700mbk	40	230/370	57	1750	400

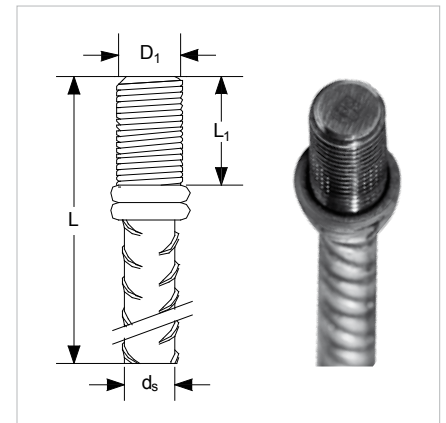

To guarantee a reliable force transfer, the threaded spigot must be tightened with a torque wrench to the torque (M) given in Tab. 2. If the reinforcing bar needs to be bent, always comply with the bending radii specified in the respective national standard for reinforced concrete.
Torque wrenches available on request.

The Schroeder rebar coupler with socket can be used to connect reinforcing bars and also as a lifting socket.

The threaded sockets are electrogalvanised with a 4-6 µm zinc coating. They can also be supplied in stainless steel or mechanically zinc plated.

Custom versions on request.
Errors and omissions excepted.
Position as of Jan 2015

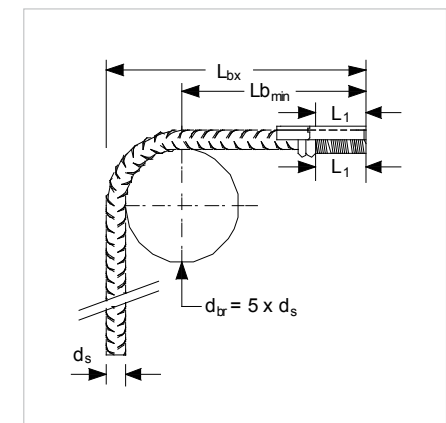

1. Description

1.1 General

Schroeder rebar couplers can be used to transfer forces safely between adjacent concrete elements.

Schroeder rebar couplers consist of two elements: The socket bar (female part, list 37 F) is a threaded socket crimped to a steel reinforcing bar (designation for M 16, for example: Ø 12-M 16). The spigot bar (list 37 M) is a threaded spigot welded to a steel reinforcing bar.
(Designation applies to all sizes \uparrow .)

1.2 Material properties

Reinforcing steel : FeB 500 HWL/B500B
Threaded socket : E 355 - DIN EN 10305
Threaded spigot : grade 5.6

1.3 Accessories

Nailing plates, magnetic plates, positioning nipples, breakpins, seal caps

1.4 Approval

Schroeder rebar couplers have been tested and certified by KIWA, certificate No. K 45993 for static loads (cat1) and K56447 for dynamic loads (cat2).

2. Installation

2.1 Installing the socket bar (female part)

Fix the socket bar to the formwork with a nailing plate, glue-on plate, magnetic plate or bolt, depending on the type of formwork. During installation it is vital to make sure that the socket bar is aligned exactly in the direction of the later reinforcing bars because any deviations may result in incorrect concrete cover to or spacing of the bars in the next concrete element.

Dimensions [mm]			
Reinforcing steel Ø	Thread D ₁	L ₁	L _{bmin} /L _{bx} (see Fig. 3)
12	M 16	27	100/140
16	M 20	33	125/180
20	M 24	38	140/210
25	M 30	43	190/275
32	M 42	65	210/325
40	M 48	52	230/370

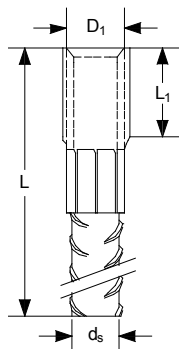

Tab./Fig. 1: Dimensions of socket bar

2.2 Installing the spigot bar (male part)

Screw the spigot bar into the socket bar. In order to guarantee a reliable force transfer, tighten and check the connection with a torque wrench (tighten with a torque M [Nm] = $5 \times d_s$ [mm], see Tab. 2).

Dimensions [mm]				[NM]
Reinf. steel Ø	Thread D ₁	L ₁	L _{bmin} /L _{bx} (see Fig. 3)	Torque
12	M 16	30	85/130	60
16	M 20	40	112/170	80
20	M 24	46	137/210	100
25	M 30	50	160/250	125
32	M 42	70	210/325	160
40	M 48	57	230/370	400

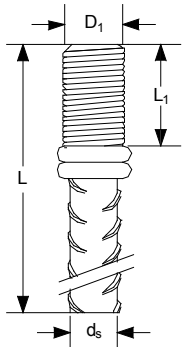

Tab./Fig. 2: Dimensions of spigot bar

Dimensions [mm]		
Reinforcing steel Ø	Thread D ₁	Bending roller Ø
12	M 16	60
16	M 20	80
20	M 24	100
25	M 30	125
32	M 42	160
40	M 48	200

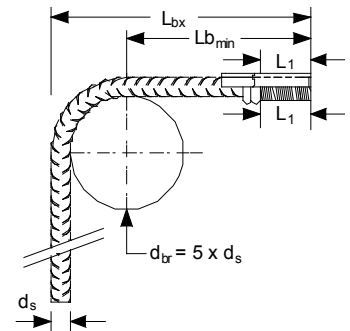

Tab./Fig. 3: Bending roller Ø

2.3 Bending the reinforcing bar

If the reinforcing bar needs to be bent, always comply with the bending radii specified in the respective national standard for reinforced concrete. To avoid damage, do not use a bending roller diameter less than $d_{br} = 5 \times d_s$. The minimum clearance to the weld seam and the threaded socket must be as given in Tabs. 1 and 2.

2.4 Inspection prior to installation

Inspect both threaded parts for cleanliness prior to screwing them together. Clean if necessary.

Prior to installation, store the bars in a dry place protected against external influences.

Prior to installing rebar couplers, check that they comply with the order, that the Schroeder mark is on both socket and spigot and that there are no obvious signs of damage.



Lifting socket

with hexagon-head bolt,
with or without end plate

38

Dimensions

Lifting sockets with bolt, without end plate

Load group	Dimensions [mm] Mild steel (bk) / Stainless steel (va)				approx. weight per 100 pieces
	d x L	Order No.	g	Bolt	
0.5	M 12 x 55	k38291205bk/va	23	M 12 x 25	5.00
0.5	M 12 x 100	k38291210bk/va	23	M 12 x 70	9.00
0.5	M 12 x 150	k38291215bk/va	23	M 12 x 120	15.00
1.2	M 16 x 75	k38291607bk/va	29	M 16 x 35	14.00
1.2	M 16 x 140	k38291614bk/va	29	M 16 x 100	24.00
1.2	M 16 x 220	k38291622bk/va	29	M 16 x 180	38.00
2.0	M 20 x 90	k38292009bk/va	35	M 20 x 40	30.00
2.0	M 20 x 150	k38292015bk/va	35	M 20 x 100	41.00
2.0	M 20 x 180	k38292018bk/va	35	M 20 x 130	46.00
2.0	M 20 x 270	k38292027bk/va	35	M 20 x 220	75.00
2.5	M 24 x 200	k38292420bk/va	45	M 24 x 140	78.00
4.0	M 30 x 240	k38293024bk/va	60	M 30 x 160	156.00
6.3	M 36 x 300	k38293630bk/va	74	M 36 x 200	270.00

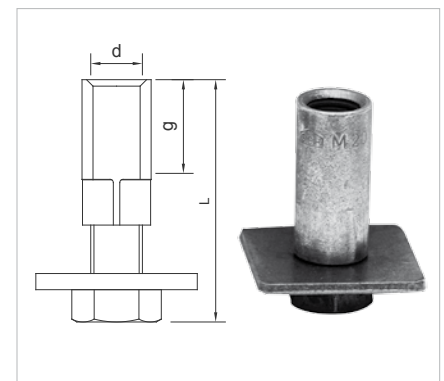
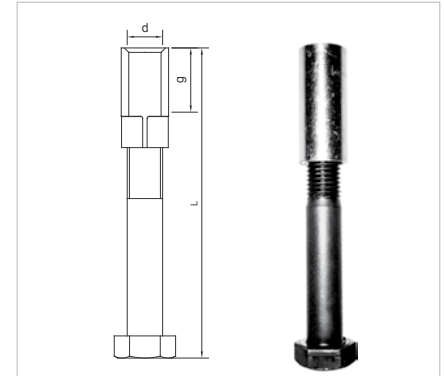

Dimensions

Lifting sockets with bolt and end plate

Load group	Dimensions [mm] Mild steel (bk) / Stainless steel (va)					approx. weight per 100 pieces
	d x L	Order No.	g	Bolt	Plate	
0.5	M 12 x 55	k38291205abk/va	23	M 12 x 25	40 x 40 x 4	10.00
1.2	M 16 x 75	k38291607abk/va	29	M 16 x 35	50 x 50 x 5	22.00
2.0	M 20 x 90	k38292009abk/va	35	M 20 x 40	60 x 60 x 5	41.50
2.5	M 24 x 110	k38292411abk/va	46	M 24 x 65	80 x 80 x 6	87.70
4.0	M 30 x 140	k38293014abk/va	60	M 30 x 60	95 x 95 x 6	134.00

Threaded socket with hexagon-head bolt
Owing to its small depth, this socket is particularly suitable for casting into slab-type elements perpendicular to the plane of the slab.

Material

Lifting sockets made from steel tube for precision applications to DIN EN 10305 (grade E 355+N). Available in mild steel or electrogalvanised steel with 4-6 µm coating thickness. Stainless steel according to approval Z-30.3-6 from 22 April 2014, grades 1.4401, 1.4404 and 1.4571. Mild steel hexagon-head bolt, grade 8.8.

On request our lifting sockets can be given a 4-6 µm electrogalvanic coating plus yellow chromate conversion coating.

The thread is cut oversize.

All dimensions can be supplied with knuckle (Rd) thread.

Custom versions on request.
Errors and omissions excepted.
Position as of Jan 2015



Permissible loads

Lifting sockets with bolt, without end plate

Load group	Type	Typical installation situation		Permissible loads for installation perpendicular to plane of slab	
		Element thickness t_{cr}	Edge distance c_{cr}	Axial pull $F_{V,perm}$	Inclined pull $F_{S,zul} \leq 45^\circ$
	[M/Rd]	[cm]		[kN]	
Concrete strength $f_{ck} \geq 15 \text{ N/mm}^2$					
0.5	12 x 55	8	9	5.1	
	12 x 100	12	15	8.6	
	12 x 150	17	23	8.6	
1.2	16 x 75	10	12	8.2	
	16 x 140	20	20	12.8	
	16 x 220	24	25	12.8	
2.0	20 x 90	15	25	10.6	
	20 x 150	20	30	20.0	
	20 x 180	20	35	20.0	
	20 x 270	29	40	20.0	
2.5	24 x 200	22	30	28.8	
4.0	30 x 240	26	35	48.3	
6.3	36 x 300	32	45	68.8	

Concrete strength $f_{ck} \geq 25 \text{ N/mm}^2$					
0.5	12 x 55	8	9	6.6	
	12 x 100	12	15	11.1	
	12 x 150	17	23	11.1	
1.2	16 x 75	10	12	10.6	
	16 x 140	20	20	16.5	
	16 x 220	24	25	16.5	
2.0	20 x 90	15	25	13.7	
	20 x 150	20	30	25.8	
	20 x 180	20	35	25.8	
	20 x 270	29	40	25.8	
2.5	24 x 200	22	30	37.2	
4.0	30 x 240	26	35	62.4	
6.3	36 x 300	32	45	88.8	

Permissible loads, sockets with bolt and end plate

Concrete strength $f_{ck} \geq 15 \text{ N/mm}^2$					
0.5	12 x 55	8	9	7.6	
1.2	16 x 75	10	12	11.9	
2.0	20 x 90	15	25	15.6	
2.5	24 x 110	22	30	27.4	
4.0	30 x 140	26	35	31.4	

Concrete strength $f_{ck} \geq 25 \text{ N/mm}^2$					
0.5	12 x 55	8	9	9.8	
1.2	16 x 75	10	12	15.4	
2.0	20 x 90	15	25	20.1	
2.5	24 x 110	22	30	35.3	
4.0	30 x 140	26	35	40.5	

Load groups

The loading categories changed when the European Machinery Directive and VDI/BV-BS Guideline 6205 (lifting inserts/systems for PCC elements) came into force.

The load group is stamped on every anchor. Given the load group and the defined typical boundary conditions in the table, it is possible to determine the permissible load of every anchor.

Level of safety

The permissible loads of lifting sockets include factors of safety $\gamma_{conc} = 2.5$ against concrete failure and $\gamma_{steel} = 3.0$ against steel failure. If the lifting sockets are not cast into concrete elements under permanently quality-controlled factory conditions, then $\gamma_{conc} = 3.0$. The permissible loads must then be multiplied by the factor 0.84.

The loads were determined at government materials-testing laboratories.

Element geometry

The permissible loads given in the tables are valid for the associated edge distances and element thicknesses ($s_{cr} \geq 2 \times c_{cr}$ then applies for the centre-to-centre spacing between two lifting sockets). However, these are not minimum spacings.

The permissible loads might need to be increased or decreased for other mounting conditions.

Just ask us - we'd be delighted to help you.

Minimum reinforcement

The permissible loads were determined with the sockets cast into concrete elements without the structural reinforcement required. Slab-type elements require two layers of Q 188 mesh as structural reinforcement.

See the table "Additional reinforcement for axial pull perpendicular to plane of element for lifting sockets with bolt and end plate".

Converting kN to t

A body with a mass of 1.0 t has a weight of approx. 10 kN.

Permissible shear forces on request.

Additional reinforcement for axial pull perpendicular to plane of element for lifting sockets with bolt and end plate

Thread [M/Rd]	Minimum reinforcement	Additional reinforcement*, B500B, axial pull [mm]			
		$n \times d_s$	L_s	L_o	L_{sum}
12	Q188 A	2 x 6	60	60	250
16	Q188 A	2 x 8	70	90	420
20	Q188 A	4 x 8	80	90	640
24	Q188 A	4 x 10	100	90	640
30	Q257 A	4 x 12	110	110	830

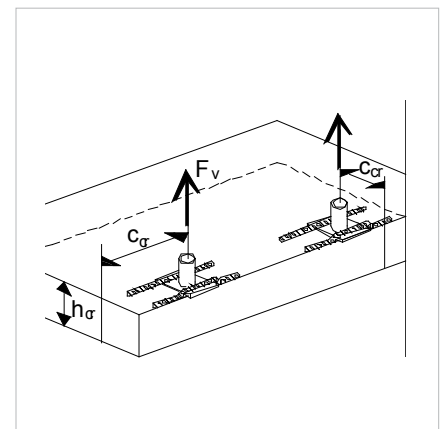
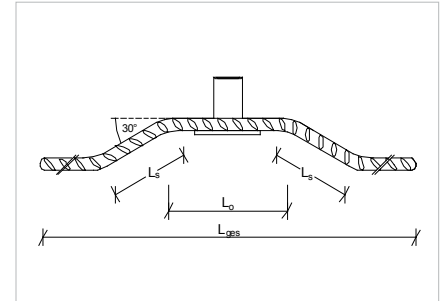

Additional reinforcement for inclined pull in plane of element

Thread [Rd]	Additional reinforcement*, B500B, inclined pull [mm]		
	d_s	D_{min}	L
12	8	32	130
16	8	32	170
20	10	40	220
24	10	40	240
30	14	56	265
36	14	56	285

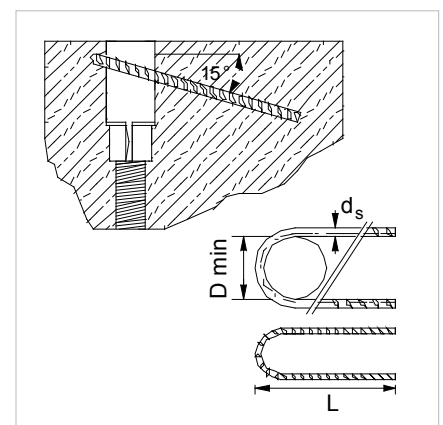
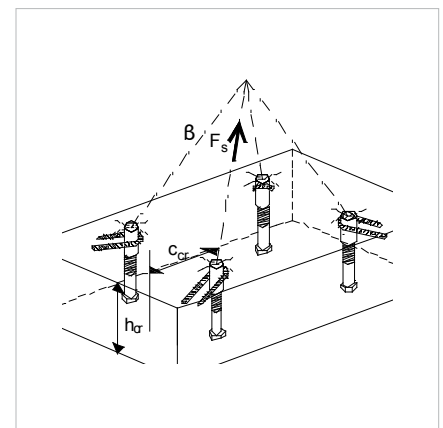

*The additional reinforcement must press against the socket.

Load group	Length	Dimensions [mm]				weight [kg]
	L	Order No.	Ø d	Ø d ₁	Ø d ₂	
1.3	40	k39101040	10	19	25	0.05
1.3	65	k39101065	10	19	25	0.07
1.3	85	k39101085	10	19	25	0.08
1.3	120	k39101120	10	19	25	0.10
1.3	240	k39101240	10	19	25	0.17
2.5	55	k39103055	14	26	35	0.13
2.5	85	k39103085	14	26	35	0.17
2.5	120	k39103120	14	26	35	0.21
2.5	140	k39103140	14	26	35	0.23
2.5	170	k39103170	14	26	35	0.27
2.5	280	k39103280	14	26	35	0.40
5.0	85	k39105085	20	36	50	0.36
5.0	95	k39105095	20	36	50	0.40
5.0	120	k39105120	20	36	50	0.46
5.0	140	k39105140	20	36	50	0.49
5.0	160	k39105160	20	36	50	0.56
5.0	180	k39105180	20	36	50	0.61
5.0	210	k39105210	20	36	50	0.69
5.0	240	k39105240	20	36	50	0.76
5.0	340	k39105340	20	36	50	1.01
5.0	480	k39105480	20	36	50	1.36
7.5	200	k39107200	24	47	60	1.01
7.5	300	k39107300	24	47	60	1.36
7.5	540	k39107540	24	47	60	2.24
10.0	170	k39110170	28	47	70	1.18
10.0	220	k39110220	28	47	70	1.44
10.0	250	k39110250	28	47	70	1.56
10.0	340	k39110340	28	47	70	1.98
15.0	165	k39115165	34	70	85	1.97
15.0	200	k39115200	34	70	85	2.21
15.0	300	k39115300	34	70	85	2.91
15.0	400	k39115400	34	70	85	3.59
20.0	500	k39120500	39	70	98	5.87

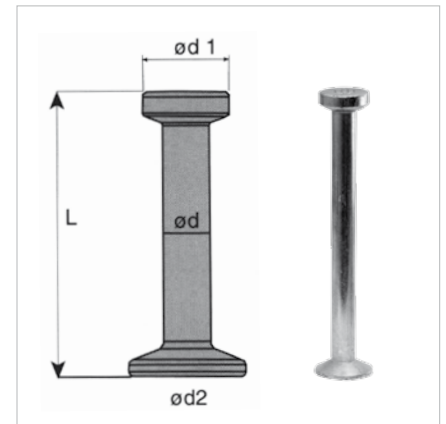

Ordering example
 Spherical head anchor,
 load 2 t, 85 mm long
 mild steel = k39102085bk
 electrogalvanised = k39102085zn
 hot-dip galvanised = k39102085fzn

Errors and omissions excepted.
 Position as of Jan 2015

Lifting clutch with standard coupling (Starcon)

Load group	Order No.	Dimensions [mm]	
		Ø	L
1.0 - 1.3	k392010131	40	105
1.5 - 2.5	k392030251	55	140
3.0 - 5.0	k392050501	60	155
6.0 - 10.0	k392101001	100	232
12.0 - 20.0	k392202001	120	292



Lifting clutch with chain coupling (Starcon)

Load group	Order No.	Dimensions [mm]		
		L	H	B
1.0 - 1.3	k392010133	173	110	50
1.5 - 2.5	k392030253	210	120	60
3.0 - 5.0	k392050503	237	120	60
6.0 - 10.0	k392101003	380	200	100
12.0 - 20.0	k392202003	484	250	120

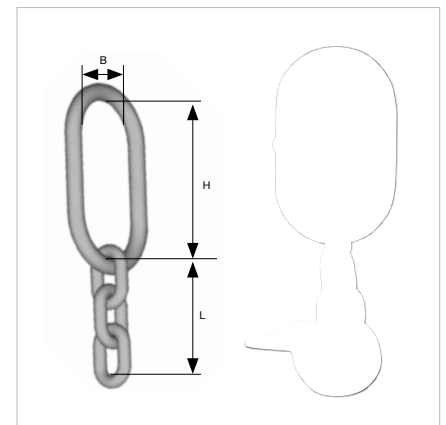

Errors and omissions excepted.
Position as of Jan 2015

Load group	Order No.	Colour	Dimensions [mm]		Weight [kg]
			d	R	
without steel parts					
1.0 - 1.3	k393010130	violet	10	30	0.10
1.5 - 2.5	k393030250	green	14	37	0.20
3.0 - 5.0	k393050500	red	20	47	0.40
6.0 - 7.5	k393070750	orange	24	59	0.70
8.0 - 10.0	k393101000	orange	28	59	0.70
incl. steel part, thread, plate, wingnut					
1.0 - 1.3	k393010131	violet	10	30	0.10
1.5 - 2.5	k393030251	green	14	37	0.20
3.0 - 5.0	k393050501	red	20	47	0.40
6.0 - 7.5	k393070751	orange	24	59	0.70
8.0 - 10.0	k393101001	orange	28	59	0.70
incl. steel part, internal thread					
1.0 - 1.3	k393010132	violet	10	30	0.10
1.5 - 2.5	k393030252	green	14	37	0.20
3.0 - 5.0	k393050502	red	20	47	0.40
6.0 - 7.5	k393070752	orange	24	59	0.70
8.0 - 10.0	k393101002	orange	28	59	0.70

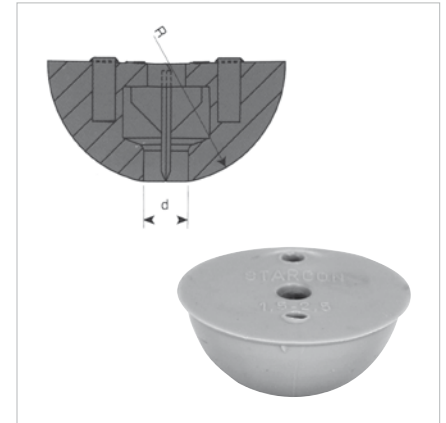

Material

Rubber

These rubber recess formers are available in different colours for different load groups.

Errors and omissions excepted.
Position as of Jan 2015



GOLIATH lifting loop

with forged head for lifting and transporting

40.0

circle shape

Load group	Dimensions [mm]							approx. weight, each [kg]	Loading capacity with safety factor of 4		
	d [mm]	Order No.	D	L	s	g	k		Axial pull $permF_V$	Inclined pull $permF_S$	90° pull $permF_Q$
									[kN]	[kN]	[kN]
0.4	M 10	k40100m	24	150	8	15	60	0.33	13	6.5	
0.5	M/Rd 12	k40120m/r	24	150	8	15	60	0.32	17	8.5	
0.8	M/Rd 14	k40140m/r	24	150	8	20	60	0.33	18	9	
1.2	M/Rd 16	k40160m/r	24	170	9	20	60	0.40	23	11.5	
1.6	Rd 18	k40180r	44	210	12	25	102	1.32	37	18.5	
2.0	M/Rd 20	k40200m/r	44	210	12	25	102	1.34	44	22	
2.5	M/Rd 24	k40240m/r	44	270	14	30	102	1.74	55	27.5	
3.0	M/Rd 27	k40270m/r	44	290	16	35	102	2.16	64	32	
4.0	M/Rd 30	k40300m/r	44	290	16	35	102	2.12	72	36	
6.3	M/Rd 36	k40360m/r	75	400	20	50	170	6.79	100	50	

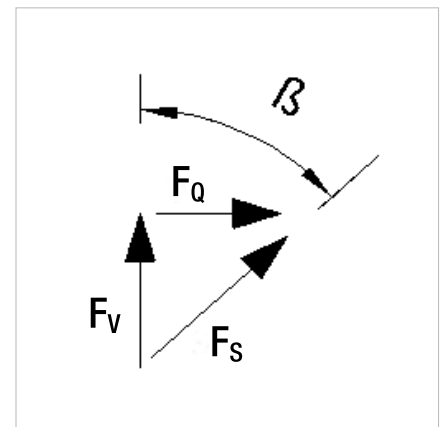
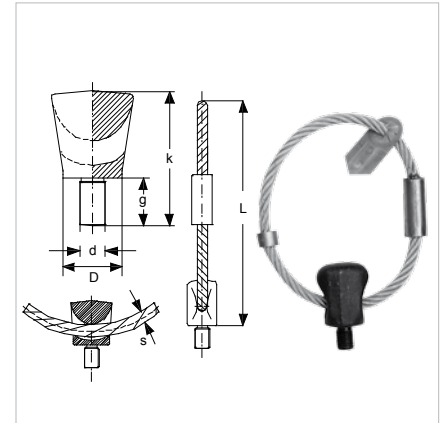

Loading capacity is the maximum load according to the "Safety rules for lifting sockets and systems for precast concrete elements". The figures include all safety factors for rope failure (4), steel failure (3) and concrete failure (3).

The head must be screwed on tightly. Every loop within the Schroeder lifting socket system carries a tag showing the manufacturer, thread and load group, ensuring correct identification.

The tags for identifying
- means of lifting (lifting loops) and
- lifting sockets
as well as the nailing plates (list 51) have the same colour for each thread size.
The requirements of the "Safety rules for lifting sockets and systems for precast concrete elements" plus the instructions for installation and use must be complied with.

The permissible loading capacities of the lifting sockets must not be exceeded.

Converting kN to t
A body with a mass of 1.0 t has a weight of approx. 10 kN.

Custom versions on request.
Errors and omissions excepted.
Position as of Jan 2015





GOLIATH lifting loop

with forged head for lifting and transporting

40.8

figure-of-eight shape

Load group	Dimensions [mm]							approx. weight, each [kg]	Permissible load with safety factor of 4		
	d [mm]	Order No.	D	L	s	g	k		Axial pull $perm F_V$	Inclined pull $perm F_S$	90° pull $perm F_Q$
									[kN]	[kN]	[kN]
0.4	M 10	k40108m	24	335	8	15	60	0.40	13	6.5	
0.5	M/Rd 12	k40128m/r	24	335	8	15	60	0.40	17	8.5	
0.8	M/Rd 14	k40148m/r	24	335	8	20	60	0.40	18	9	
1.2	M/Rd 16	k40168m/r	24	365	9	20	60	0.50	23	11.5	
1.6	M/Rd 18	k40188r	44	470	12	25	102	1.55	37	18.5	
2.0	M/Rd 20	k40208m/r	44	470	12	25	102	1.57	44	22	
2.5	M/Rd 24	k40248m/r	44	550	14	30	102	2.10	55	27.5	
3.0	M/Rd 27	k40278m/r	44	590	16	35	102	2.60	64	32	
4.0	M/Rd 30	k40308m/r	44	590	16	35	102	2.60	72	36	
6.3	M/Rd 36	k40368m/r	75	780	20	50	170	7.68	102	50	
8.0	M/Rd 42	k40308m/r	75	860	22	60	180	8.99	110	55	
12.5	M/Rd 52	k40368m/r	75	1080	28	70	190	15.20	175	87.5	

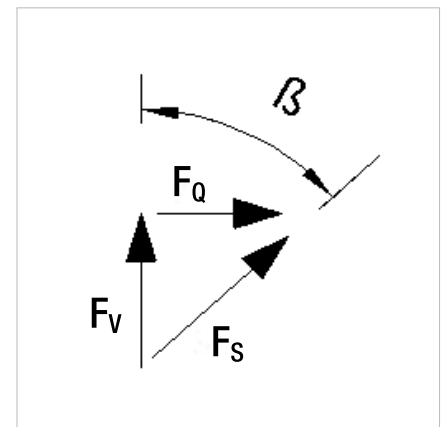
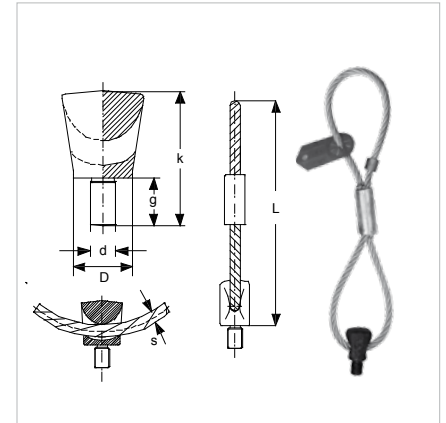

Loading capacity is the maximum load according to the "Safety rules for lifting sockets and systems for precast concrete elements". The figures include all safety factors for rope failure (4), steel failure (3) and concrete failure (3).

The head must be screwed on tightly. Every loop within the Schroeder lifting socket system carries a tag showing the manufacturer, thread and load group, ensuring correct identification.

The tags for identifying
- means of lifting (lifting loops) and
- lifting sockets
as well as the nailing plates (list 51) have the same colour for each thread size.
The requirements of the "Safety rules for lifting sockets and systems for precast concrete elements" plus the instructions for installation and use must be complied with.

The permissible loading capacities of the lifting sockets must not be exceeded.

Converting kN to t
A body with a mass of 1.0 t has a weight of approx. 10 kN.

Custom versions on request.
Errors and omissions excepted.
Position as of Jan 2015

Load group	Metric thread		Knuckle thread with metric pitch		Dimensions [mm]					approx. weight, each [kg]	Loading capacity with safety factor of 4	
	d [mm]	Order No.	d [mm]	Order No.	B	H	g	L	S		Axial pull perm F_V	90° pull perm F_Q
											Inclined pull perm F_S	[kN]
0.4	M 10	k4110m			55	42	22	260	8	0.45	13	6.5
0.5	M 12	k4112m	Rd 12	k4112r	55	42	24	260	8	0.45	17	8.5
0.8	M 14	k4114m	Rd 14	k4114r	55	42	25	260	8	0.47	18	9
1.2	M 16	k4116m	Rd 16	k4116r	55	42	28	320	10	0.65	23	11.5
1.6			Rd 18	k4118r	89	69	32	380	12	1.45	37	18.5
2.0	M 20	k4120m	Rd 20	k4120r	89	69	34	380	12	1.50	44	22
2.5	M 24	k4124m	Rd 24	k4124r	89	69	39	430	14	1.65	55	27.5
3.0	M 27	k4127m			89	69	42	490	16	2.50	64	32
4.0	M 30	k4130m	Rd 30	k4130r	89	69	46	490	16	2.50	72	36

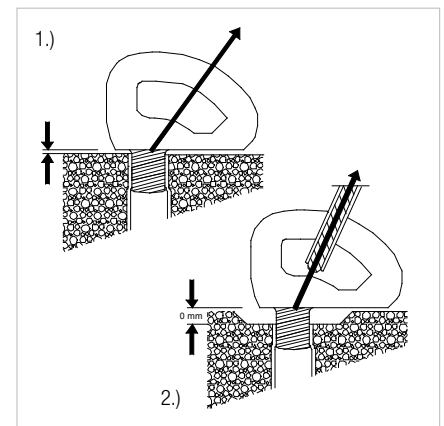
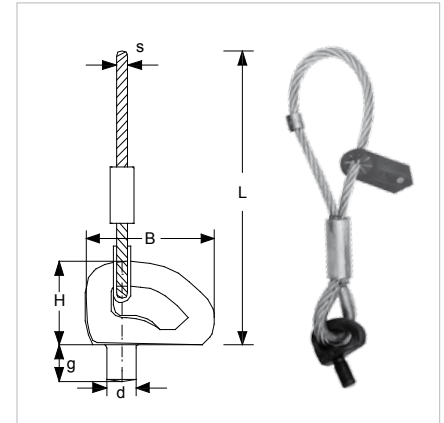

1.) After screwing fully into the socket, the forged head may be turned back by no more than one full turn to match the direction of pull.

2.) No reduction in the permissible loading capacity when using 10 mm plastic nailing plates (list 51) even if the head cannot be screwed in fully.

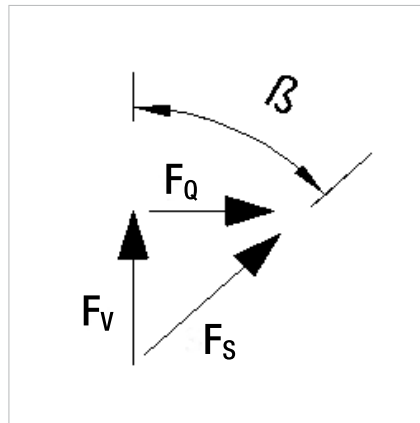

Loading capacity is the maximum load according to the "Safety rules for lifting sockets and systems for precast concrete elements". The figures include all safety factors for rope failure (4), steel failure (3) and concrete failure (3).

The head must be screwed on tightly. Every loop within the Schroeder lifting socket system carries a tag showing the manufacturer, thread and load group, ensuring correct identification.

The tags for identifying
- means of lifting (lifting loops) and
- lifting sockets
as well as the nailing plates (list 51) have the same colour for each thread size. The requirements of the "Safety rules for lifting sockets and systems for precast concrete elements" plus the instructions for installation and use must be complied with.

The permissible loading capacities of the lifting sockets must not be exceeded.

Converting kN to t
A body with a mass of 1.0 t has a weight of approx. 10 kN.

Custom versions on request.
Errors and omissions excepted.
Position as of Jan 2015

Load group	Metric thread		Knuckle thread with metric pitch		Dimensions [mm]			approx. weight, each [kg]	Loading capacity with safety factor of 4 Axial pull F_{Vperm} [kN]
	d [mm]	Order No.	d [mm]	Order No.	g	L	s		
0.5	M 12	k4212m	Rd 12	k4212r	22	130	6	0.06	9.0
0.8	M 14	k4214m	Rd 14	k4214r	25	150	7	0.10	14.0
1.2	M 16	k4216m	Rd 16	k4216r	27	170	8	0.13	17.0
1.6			Rd 18	k4218r	34	190	9	0.19	24.0
2.0	M 20	k4220m	Rd 20	k4220r	35	210	10	0.26	31.0
2.5	M 24	k4224m	Rd 24	k4224r	43	260	12	0.43	39.0
3.0	M 27	k4227m			48	280	13	0.67	49.0
4.0	M 30	k4230m	Rd 30	k4230r	56	340	16	1.05	50.0
6.3	M 36	k4236m	Rd 36	k4236r	68	380	18	1.52	79.0
8.0	M 42	k4242m	Rd 42	k4242r	80	420	20	2.18	102.0
12.5	M 52	k4252m	Rd 52	k4252r	97	550	26	4.75	175.0

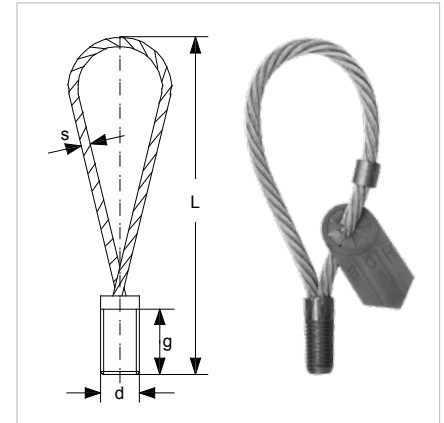

Every loop within the Schroeder lifting socket system carries a tag showing the manufacturer, thread and load group, ensuring correct identification.

The tags for identifying
 - means of lifting (lifting loops) and
 - lifting sockets
 as well as the nailing plates (list 51) have the same colour for each thread size.
 The requirements of the "Safety rules for lifting sockets and systems for precast concrete elements" plus the instructions for installation and use must be complied with.

Custom versions on request.
 Errors and omissions excepted.
 Position as of Jan 2015

PLEASE NOTE!
 Only suitable for inclined pull up to max. 45°.

Inclined pull up to max. 45° in conjunction with the various lifting socket products.

Load group	Thread Ø	Order No.	Rope Ø	Total length	Loading capacity with safety factor of 4 Axial pull F_{Vperm} [kN]
	M		s	L	
	[mm]		[mm]	[mm]	[kN]
0.5	12	k420500	7	200	14.0
1.2	16	k421200	10	250	31.0
2.5	24	k422500	16	350	50.0

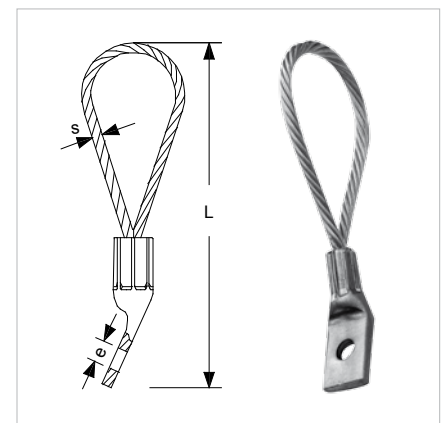

The given loading capacities are valid when fixing with a grade 8.8 hexagon-head bolt.



Eyebolt (DIN 580)

without chain link, for lifting and transporting

43

Dimensions [mm]						Permissible load F_v [kN]
Mild steel (bk) / Galvanised + chromated steel (zn)						
d_1	Order No.	d_3	d_4	h	L	
M 8	k4308bk/zn	36	20	36	13	1.4
M 10	k4310bk/zn	45	25	45	17	2.3
M 12	k4312bk/zn	54	30	53	20	3.4
M 14	k4314bk/zn	63	35	62	27	4.5
M 16	k4316bk/zn	63	35	62	27	7.0
M 20	k4320bk/zn	72	40	71	30	12.0
M 24	k4324bk/zn	90	50	90	36	18.0
M 27	k4327bk/zn	90	50	90	36	24.0
M 30	k4330bk/zn	108	60	109	45	36.0

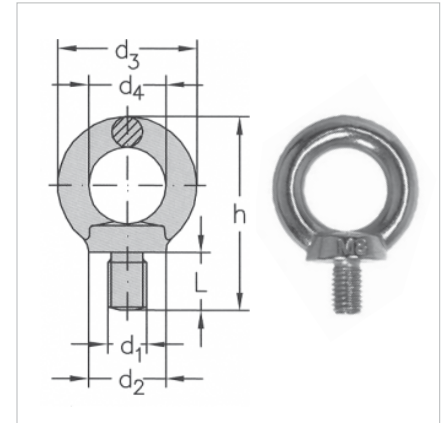

Connection loop

for joining precast elements

53

Dimensions [mm]				approx. weight per 100 pcs. [kg]	Permissible load F_v (safety factor 4-5) [kN]
Mild steel (bk)/Galvanised+chromated steel (zn)		Internal dims. width x height	Thread length g		
d x L	Order No.				
M 10 x 100	K5310bk/zn	34 x 65	15	9.60	7.5
M 12 x 100	K5315bk/zn	34 x 65	20	11.40	9.0
M 12 x 125	K5320bk/zn	45 x 85	20	12.80	9.0
M 16 x 120	K5325bk/zn	45 x 85	30	16.00	10.0
M 16 x 140	K5330bk/zn	45 x 85	30	18.00	10.0
M 16 x 175	K5335bk/zn	45 x 130	30	20.00	10.0
M 16 x 235	K5340bk/zn	45 x 180	30	25.00	10.0

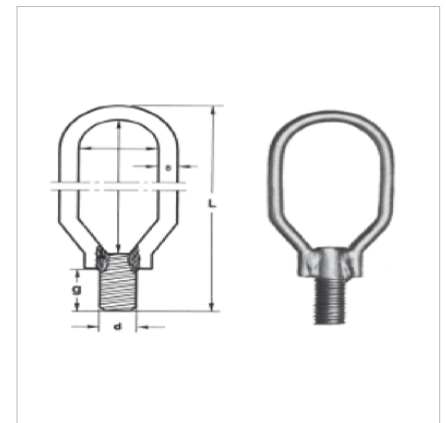

Connection loops can be used to create structural connections at joints between precast concrete elements and are also used for the subsequent positioning of intermediate walls.

Custom versions on request.
Errors and omissions excepted.
Position as of Jan 2015

Plastic (nailing plate)

Dimensions [mm]	Order No.
d	
M + Rd 8	k5108kh
M + Rd 10	k5110kh
M + Rd 12	k5112kh
M + Rd 14	k5114kh
M + Rd 16	k5116kh
M + Rd 18	k5118kh
M + Rd 20	k5120kh
M + Rd 24	k5124kh
M + Rd 27	k5127kh
M + Rd 30	k5130kh
Removal tool	k5100kh



Magnetic

Dimensions [mm]	Order No.
d	
M + Rd 8	k5108mh
M + Rd 10	k5110mh
M + Rd 12	k5112mh
M + Rd 14	k5114mh
M + Rd 16	k5116mh
M + Rd 18	k5118mh
M + Rd 20	k5120mh
M + Rd 24	k5124mh
M + Rd 27	k5127mh
Removal tool	k5100mh



Plastic (adhesive plate)

Dimensions [mm]	Order No.
d	
M + Rd 10	k5110kt
M + Rd 12	k5112kt
M + Rd 14	k5114kt
M + Rd 16	k5116kt
M + Rd 18	k5118kt
M + Rd 20	k5120kt
M + Rd 24	k5124kt



Plastic (breakpin)

Dimensions [mm]		Order No.
d		
M 6	11	k5306ku
M 8	11	k5308ku
M 10	11	k5310ku
M 12	11	k5312ku
M 16	17	k5316ku
M 20	17	k5320ku
M 24	17	k5324ku

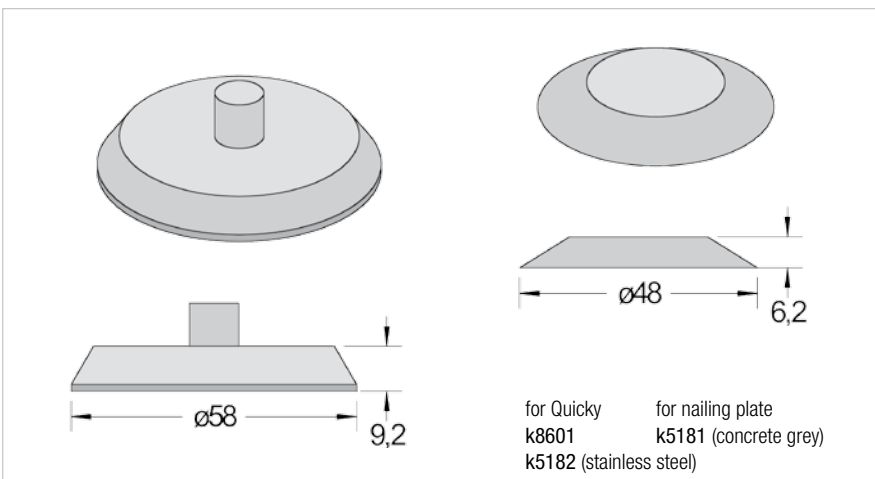

Fire-resistant adhesive
 310 ml, incombustible material (building materials class A1 to DIN 4102-1).
 For internal use only, order No. k5180.

For gluing into recesses for nailing plates and Quickys.

Custom versions on request.
 Errors and omissions excepted.
 Position as of Jan 2015

without thread

Size [mm]	Order No.
M + Rd 6	k5206og
M + Rd 8	k5208og
M + Rd 10	k5210og
M + Rd 12	k5212og
M + Rd 14	k5214og
M + Rd 16	k5216og
M + Rd 18	k5218og
M + Rd 20	k5220og
M + Rd 24	k5224og
M + Rd 27	k5227og
M + Rd 30	k5230og
M + Rd 36	k5236og
M + Rd 42	k5242og
M + Rd 52	k5252og

with thread

Size [mm]	Order No.
M + Rd 8	k5208mg
M + Rd 10	k5210mg
M + Rd 12	k5212mg
M + Rd 14	k5214mg
M + Rd 16	k5216mg
M + Rd 20	k5220mg
M + Rd 24	k5224mg



Mounting accessory

for unitised walls

Quicky*

For inclined props supporting concrete walls during construction.
Suitable for applications in thin double walls, heavyweight elements and lightweight concrete walls.
The Quicky adhesive base includes an integral predetermined breaking point.

Material: plastic
Disc diameter: 46 mm
Length: 74 mm

Order No. k8600
*patented



Custom versions on request.
Errors and omissions excepted.
Position as of Jan 2015



Schroeder Flexi double-wall lifting anchor

mild steel grade S235 with wavy tail

86

-1-

Dimensions

Load group	Dimensions [mm]				approx. weight, each [kg]	Pieces/pallet
	L ₁ x H ₁	Order No.	D ₂	D		
25	120 x 450	k861120	20	14	1.38	500
25	130 x 450	k861130	20	14	1.40	500
25	140 x 450	k861140	20	14	1.42	500
25	150 x 450	k861150	20	14	1.48	500
25	160 x 450	k861160	20	14	1.54	400
25	170 x 450	k861170	20	14	1.58	400
25	180 x 450	k861180	20	14	1.62	400
25	190 x 450	k861190	20	14	1.66	400
25	200 x 450	k861200	20	14	1.70	400
25	210 x 450	k861210	22	14	1.77	300
25	220 x 450	k861220	22	14	1.80	300
25	230 x 450	k861230	22	14	1.84	300
25	240 x 450	k861240	22	14	1.86	300
25	250 x 450	k861250	22	14	1.88	300
25	260 x 450	k861260	22	14	1.90	300
25	270 x 450	k861270	22	14	1.95	300
25	280 x 450	k861280	22	14	2.00	300
25	290 x 450	k861290	22	14	2.05	300
25	300 x 450	k861300	22	14	2.10	300
25	310 x 450	k861310	22	14	2.15	200
25	320 x 500	k861320	25	14	2.52	200
25	340 x 500	k861340	25	14	2.58	200
25	360 x 500	k861360	25	14	2.64	200

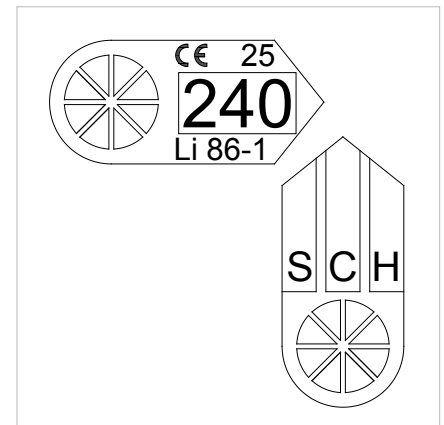
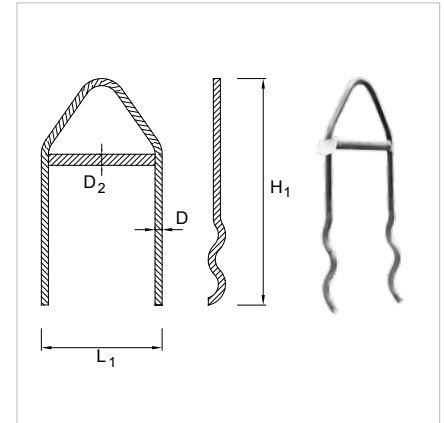

Double-wall anchors are used for transporting and positioning double-wall units. Their wavy-tail bars anchor them in the concrete.

This product complies with the requirements of VDI/BV-BS Guideline 6205 and the European Machinery Directive 2006/42/EC.

Material: mild steel S235

Load groups

The loading categories changed when the European Machinery Directive and VDI/BV-BS Guideline 6205 (lifting inserts/systems for PCC elements) came into force.

The load group is marked on every anchor. Given the load group and the defined typical boundary conditions in the table, it is possible to determine the permissible load of every anchor.

Double-wall anchors are marked with manufacturer's mark, anchor width, list number, load group and CE marking.

Custom versions on request.
Errors and omissions excepted.
Position as of Jan 2015

Notes to design table

Initial type-testing

The permissible loads were determined in tests carried out according to VDI/BV-BS 6205 (lifting inserts/ systems for PCC elements) with the support of TU Dortmund, Institute of Fastening Technology. The permissible loads for inclined and 90° pull were optimised in further tests.

Element geometry

The permissible loads given in the tables are valid for the associated edge distances and panel thicknesses ($S_{cr} \geq 2 \times c_{cr}$ then applies for the centre-to-centre spacing between two anchors). However, these are not minimum dimensions; other mounting conditions could lead to higher or lower permissible loads. **Just ask us - we'd be delighted to help you.**

Level of safety

The tests were evaluated according to method A of VDI/BV-BS 6205.

"The determination of the characteristic resistance based on method A is in accordance with DIN EN 1990, Annex D. Then the characteristic resistance is defined as the 5% fractile of the measured ultimate loads with a confidence level of 75%." (VDI/BV-BS 6205)

The permissible loads of lifting sockets include factors of safety $\gamma_{conc} = 2.1$ against concrete failure and $\gamma_{steel} = 3.0$ against steel failure. If the anchors are not cast into concrete elements under permanently quality-controlled factory conditions, then $\gamma_{conc} = 2.5$. The permissible loads must then be multiplied by the factor 0.84.

The loading tables already include the vertical element $F_{V,S}$ for inclined pull and not the inclined tensile force F_S ; a reduction using the inclined pull factor is unnecessary.

Converting kN to t

A body with a mass of 1.0 t has a weight of approx. 10 kN.

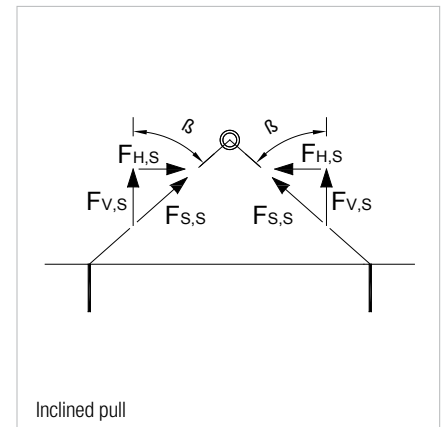

Inclined pull

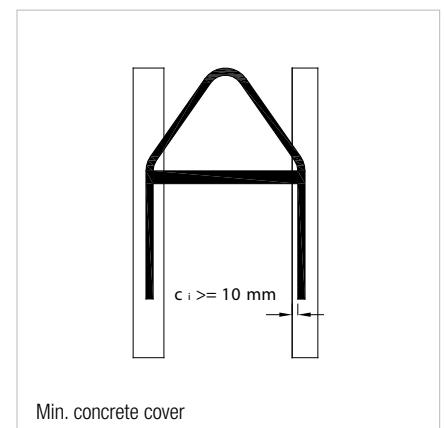

Min. concrete cover

Definition of various standard load cases

Load case 1:

Striking and transport in the factory

- Concrete strength approx. 15 N/mm² - 25 N/mm²
- Striking with tilting table and then axial pull with spreader beam or
- Striking with fork extensions and transporting horizontal slab with forklift truck
- Hoisting load factor 1.3
- No adhesion to formwork
- No inclined pull or 90° pull -> axial pull only

Load case 2:

Striking and transport in the factory

- Concrete strength approx. 15 N/mm² - 25 N/mm²
- Striking without tilting table -> Lifting horizontal slab into vertical position with 90° pull (detailed calculations required, including adhesion to formwork)
- Transport in the factory with lifting gear without spreader beam, inclined pull $\leq 45^\circ$
- Hoisting load factor 1.3
- > Inclined pull and 90° pull

Load case 3:

Transport and erection on the building site

- Concrete strength approx. 20 - 25 - 30 - 35 N/mm²
- Delivery of double-wall elements vertical in steel containers
- Lifting gear with inclined pull $\leq 45^\circ$ or 30°
- Hoisting load factor 1.3
- > Inclined pull

Load case 4:

Transport and erection on the building site

- Concrete strength approx. 20 - 25 - 30 - 35 N/mm²
- Delivery of double-wall elements lying flat on a goods vehicle
- Lifting the horizontal slabs into the vertical position with 90° pull
- Lifting gear with inclined pull $\leq 45^\circ$ or 30°
- Hoisting load factor 1.3
- > 90° pull and inclined pull

Design table, load group 25

Permissible loads and maximum permissible wall weights when using 2 or 4 anchors

Conc. strength	Permissible loads			Hoist. factor	max. wall weight							
	Axial pull F_V	Inclined pull F_S	90° pull F_Q		Load case 1		Load case 2		Load case 3		Load case 4	
					for 2 anchors	for 4 anchors	for 2 anchors	for 4 anchors	for 2 anchors	for 4 anchors	for 2 anchors	for 4 anchors
[N/mm ²]	[kN]				[t]							

1. Panel thk. h = 5.0 cm; min. concrete cover $c_1 = 1.0$ cm; edge distance c = 30.0 cm

15	25.2	23.1	7.9	1.3	4.0	7.9	2.5	5.0				
20	29.1	26.7	9.1	1.3	4.6	9.1	2.9	5.7	4.2	8.4	2.9	5.7
25	32.5	29.8	10.2	1.3	5.1	10.2	3.2	6.4	4.7	9.3	3.2	6.4
30	35.6	32.6	11.2	1.3					5.1	10.2	3.5	7.0
35	36.5	35.3	12.1	1.3					5.5	11.1	3.8	7.6

2. Panel thk. h = 6.5 cm; min. concrete cover $c_1 = 1.5$ cm; edge distance c = 30.0 cm

15	35.5	35.5	11.0	1.3	5.6	11.1	3.5	6.9				
20	36.5	36.5	12.7	1.3	5.7	11.4	4.0	8.0	5.7	11.4	4.0	8.0
25	36.5	36.5	14.2	1.3	5.7	11.4	4.5	8.9	5.7	11.4	4.5	8.9
30	36.5	36.5	15.6	1.3					5.7	11.4	4.9	9.8
35	36.5	36.5	16.8	1.3					5.7	11.4	5.3	10.5

See previous page for notes to design table.

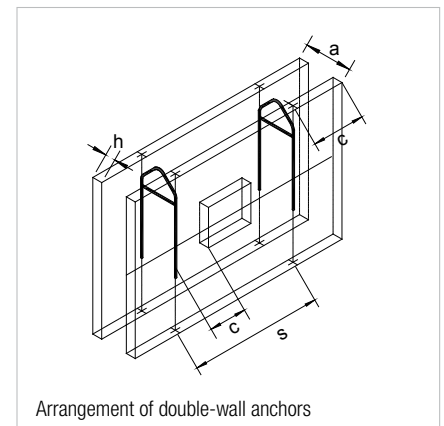
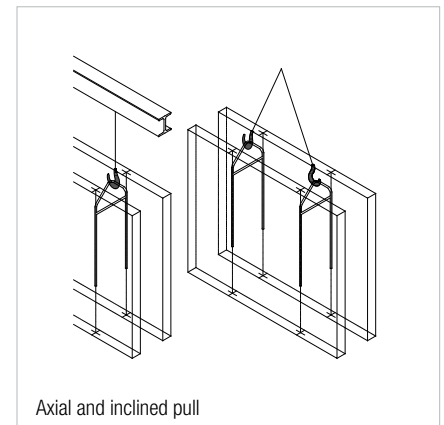
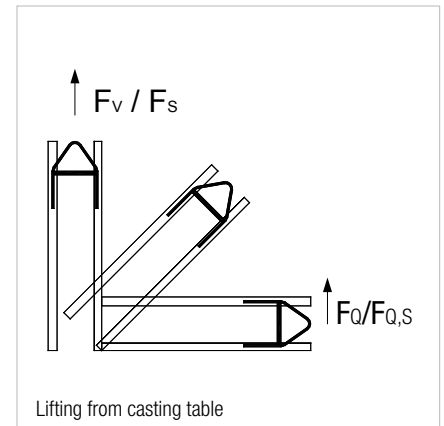

Dimensions

Load group	Dimensions [mm]				approx. weight, each [kg]	Pieces/pallet
	L ₁ x H ₁	Order No.	D ₂	D		
24	120 x 450	k862120	20	14	1.35	360
24	130 x 450	k862130	20	14	1.39	360
24	140 x 450	k862140	20	14	1.44	360
24	150 x 450	k862150	20	14	1.46	360
24	160 x 450	k862160	20	14	1.47	350
24	170 x 450	k862170	20	14	1.50	350
24	180 x 450	k862180	20	14	1.54	340
24	190 x 450	k862190	20	14	1.57	340
24	200 x 450	k862200	20	14	1.61	330
24	210 x 450	k862210	22	14	1.70	330
24	220 x 450	k862220	22	14	1.76	330
24	230 x 450	k862230	22	14	1.79	330
24	240 x 450	k862240	22	14	1.82	290
24	250 x 450	k862250	22	14	1.85	290
24	260 x 450	k862260	22	14	1.89	290
24	270 x 450	k862270	22	14	1.93	290
24	280 x 450	k862280	22	14	1.96	270
24	290 x 450	k862290	22	14	1.99	270
24	300 x 450	k862300	22	14	2.02	270
24	310 x 450	k862310	22	14	2.10	270
24	320 x 500	k862320	25	14	2.43	260
24	340 x 500	k862340	25	14	2.54	260
24	360 x 500	k862360	25	14	2.64	260

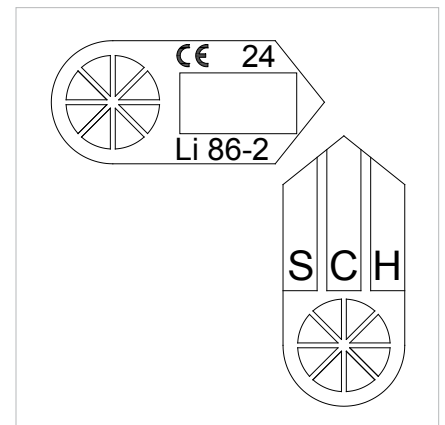
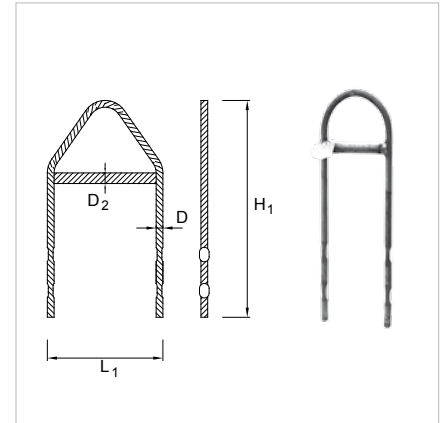

Double-wall anchors are used for transporting and positioning double-wall units. Their pressed bars anchor them in the concrete.

This product complies with the requirements of VDI/BV-BS Guideline 6205 and the European Machinery Directive 2006/42/EC.

Material: mild steel S235

Load groups

The loading categories changed when the European Machinery Directive and VDI/BV-BS Guideline 6205 (lifting inserts/systems for PCC elements) came into force.

The load group is marked on every anchor. Given the load group and the defined typical boundary conditions in the table, it is possible to determine the permissible load of every anchor.

Double-wall anchors are marked with manufacturer's mark, anchor width, list number, load group and CE marking.

Custom versions on request.
Errors and omissions excepted.
Position as of Jan 2015

Notes to design table

Initial type-testing

The permissible loads were determined in tests carried out according to VDI/BV-BS 6205 (lifting inserts/ systems for PCC elements) with the support of TU Dortmund, Institute of Fastening Technology. The permissible loads for inclined and 90° pull were optimised in further tests.

Element geometry

The permissible loads given in the tables are valid for the associated edge distances and panel thicknesses ($S_{cr} \geq 2 \times c_{cr}$ then applies for the centre-to-centre spacing between two anchors). However, these are not minimum dimensions; other mounting conditions could lead to higher or lower permissible loads. **Just ask us - we'd be delighted to help you.**

Level of safety

The tests were evaluated according to method A of VDI/BV-BS 6205.

"The determination of the characteristic resistance based on method A is in accordance with DIN EN 1990, Annex D. Then the characteristic resistance is defined as the 5% fractile of the measured ultimate loads with a confidence level of 75%." (VDI/BV-BS 6205)

The permissible loads of lifting sockets include factors of safety $\gamma_{conc} = 2.1$ against concrete failure and $\gamma_{steel} = 3.0$ against steel failure. If the lifting sockets are not cast into concrete components under permanently quality-controlled factory conditions, then $\gamma_{conc} = 2.5$. The permissible loads must then be multiplied by the factor 0.84.

The loading tables already include the vertical element $F_{v,s}$ for inclined pull and not the inclined tensile force F_s ; a reduction using the inclined pull factor is unnecessary.

Converting kN to t

A body with a mass of 1.0 t has a weight of approx. 10 kN.

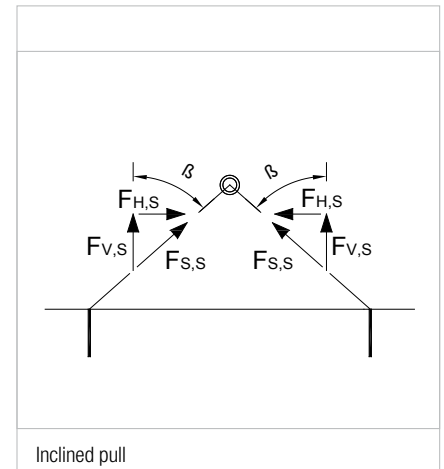

Inclined pull

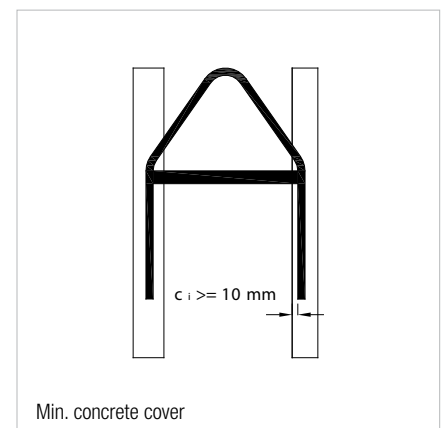

Min. concrete cover

Definition of various standard load cases

Load case 1:

Striking and transport in factory

- Concrete strength approx. 15 N/mm² - 25 N/mm²
- Striking with tilting table and then axial pull with spreader beam or
- Striking with fork extensions and transporting horizontal slab with forklift truck
- Hoisting load factor 1.3
- No adhesion to formwork
- No inclined pull or 90° pull -> axial pull only

Load case 2:

Striking and transport in factory

- Concrete strength approx. 15 N/mm² - 25 N/mm²
- Striking without tilting table -> Lifting horizontal slab to vertical position with 90° pull (detailed calculations required, including adhesion to formwork)
- Transport in the factory with lifting gear without spreader beam, inclined pull $\leq 45^\circ$
- Hoisting load factor 1.3
- > Inclined pull and 90° pull

Load case 3:

Transport and erection on building site

- Concrete strength approx. 20 - 25 - 30 - 35 N/mm²
- Delivery of double-wall elements vertical in steel containers
- Lifting gear with inclined pull $\leq 45^\circ$ or 30°
- Hoisting load factor 1.3
- > Inclined pull

Load case 4:

Transport and erection on building site

- Concrete strength approx. 20 - 25 - 30 - 35 N/mm²
- Delivery of double-wall elements lying flat on a goods vehicle
- Lifting the horizontal slabs with 90° pull into the vertical position
- Lifting gear with inclined pull $\leq 45^\circ$ or 30°
- Hoisting load factor 1.3
- > 90° pull and inclined pull

Design table, load group 24

Conc. strength	Permissible loads			Hoist. factor	max. wall weight							
	Axial pull perm F_V	Inclined pull perm F_S	90° pull perm F_Q		Load case 1		Load case 2		Load case 3		Load case 4	
					for 2 anchors	for 4 anchors	for 2 anchors	for 4 anchors	for 2 anchors	for 4 anchors	for 2 anchors	for 4 anchors
[N/mm ²]	[kN]				[t]							

Permissible loads and maximum permissible wall weights when using 2 or 4 anchors - standard installation

1. Panel thk. $h = 5.0$ cm; min. concrete cover $c_1 = 1.0$ cm; edge distance $c = 30.0$ cm												
15	23.9	23.1	8.0	1.3	3.7	7.5	2.5	5.0	3.6	7.2		
20	27.5	26.7	9.2	1.3	4.3	8.6	2.9	5.8	4.2	8.4	2.9	5.8
25	30.8	29.8	10.3	1.3	4.8	9.7	3.2	6.5	4.7	9.3	3.2	6.5
30	33.7	32.6	11.3	1.3					5.1	10.2	3.5	7.1
35	36.5	35.3	12.2	1.3					5.5	11.1	3.8	7.6

2. Panel thk. $h = 6.0$ cm; min. concrete cover $c_1 = 1.0$ cm; edge distance $c = 30.0$ cm												
15	27.1	25.0	9.6	1.3	4.2	8.5	3.0	6.0	3.9	7.8		
20	31.3	28.9	11.0	1.3	4.9	9.8	3.5	6.9	4.5	9.1	3.5	6.9
25	35.0	32.3	12.4	1.3	5.5	11.0	3.9	7.8	5.1	10.1	3.9	7.8
30	36.5	35.4	13.5	1.3					5.5	11.1	4.2	8.5
35	36.5	36.5	14.6	1.3					5.7	11.4	4.6	9.2

See previous page for notes to design table.

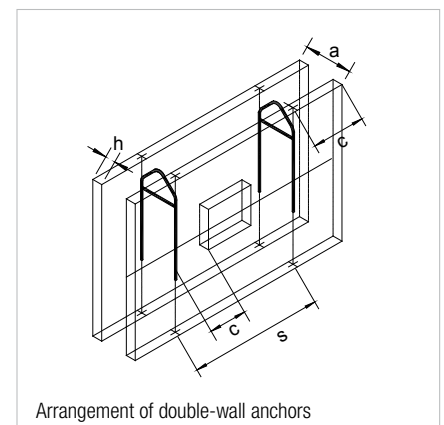
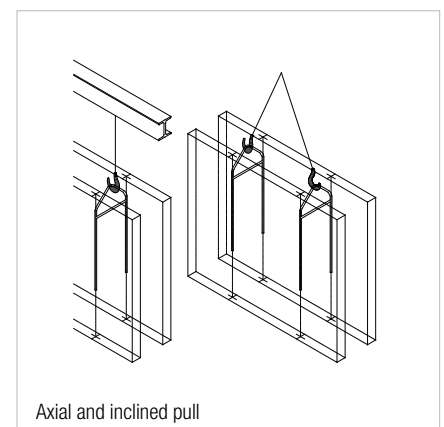
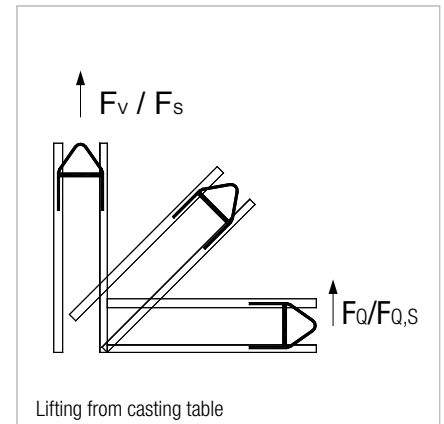



Design table, load group 24

Conc. strength	Permissible loads			Hoist. factor	max. wall weight							
	Axial pull permF _V	Inclined pull permF _S	90° pull permF _Q		Load case 1		Load case 2		Load case 3		Load case 4	
					for 2 anchors	for 4 anchors	for 2 anchors	for 4 anchors	for 2 anchors	for 4 anchors	for 2 anchors	for 4 anchors
[N/mm ²]	[kN]				[t]							

Permissible loads and maximum permissible wall weights when using 2 or 4 anchors - confined installation

1. Panel thk. h = 5.0 cm or 6.0 cm; min. concrete cover c _i = 1.0 cm; edge distance c ≥ 5.0 cm												
5 cm panel												
15	10.6	10.2	3.5	1.3	1.7	3.3	1.1	2.2	1.6	3.2		
20	12.2	11.8	4.1	1.3	1.9	3.8	1.3	2.6	1.9	3.7	1.3	2.6
25	13.6	13.2	4.6	1.3	2.1	4.3	1.4	2.9	2.1	4.1	1.4	2.9
30	14.9	14.5	5.0	1.3					2.3	4.5	1.6	3.2
6 cm panel												
15	13.8	12.8	4.9	1.3	2.2	4.3	1.5	3.1	2.0	4.0		
20	16.0	14.8	5.7	1.3	2.5	5.0	1.8	3.6	2.3	4.6	1.8	3.6
25	17.9	16.5	6.3	1.3	2.8	5.6	2.0	4.0	2.6	5.2	2.0	4.0
30	19.6	18.1	6.9	1.3					2.8	5.7	2.2	4.3

2. Panel thk. h = 5.0 cm or 6.0 cm; min. concrete cover c _i = 1.0 cm; edge distance c ≥ 15.0 cm												
5 cm panel												
15	15.1	14.6	8.0	1.3	2.4	4.7	2.5	5.0	2.3	4.6		
20	17.4	16.8	9.2	1.3	2.7	5.5	2.9	5.8	2.6	5.3	2.9	5.8
25	19.4	18.8	10.3	1.3	3.0	6.1	3.2	6.5	2.9	5.9	3.2	6.5
30	21.3	20.6	11.3	1.3					3.2	6.5	3.5	7.1
6 cm panel												
15	19.8	18.3	9.6	1.3	3.1	6.2	3.0	6.0	2.9	5.7		
20	22.9	21.1	11.0	1.3	3.6	7.2	3.5	6.9	3.3	6.6	3.5	6.9
25	25.6	23.6	12.4	1.3	4.0	8.0	3.9	7.8	3.7	7.4	3.9	7.8
30	28.0	25.9	13.5	1.3					4.1	8.1	4.2	8.5

Permissible loads and maximum permissible wall weights when using 2 or 4 Schroeder KS anchors (anchor cut off approx. 2-3 cm below crossbar) - confined installation

Panel thk. h = 5.0 cm or 6.0 cm; min. concrete cover c _i = 1.0 cm; edge distance c = 15.0 cm												
5 cm panel												
15	9.4	9.1	4.7	1.3	1.5	2.9	1.5	2.9	1.4	2.9		
20	10.9	10.5	5.5	1.3	1.7	3.4	1.7	3.4	1.6	3.3	1.7	3.4
25	12.2	11.8	6.1	1.3	1.9	3.8	1.9	3.8	1.9	3.7	1.9	3.8
30	13.4	12.9	6.7	1.3					2.0	4.1	2.1	4.2
6 cm panel												
15	12.4	11.4	6.2	1.3	1.9	3.9	1.9	3.9	1.8	3.6		
20	14.3	13.2	7.2	1.3	2.2	4.5	2.2	4.5	2.1	4.1	2.2	4.5
25	16.0	14.8	8.0	1.3	2.5	5.0	2.5	5.0	2.3	4.6	2.5	5.0
30	17.5	16.2	8.8	1.3					2.5	5.1	2.7	5.5

See previous page for notes to design table.



Dimensions

Propping socket						Adhesive plate			
Dimensions [mm]				Order No.	approx. weight, each [kg]	Material	Dimensions [mm]		
d x D	L	e	t				D	t	Order No.
16 x 50	45	42	3	S 8617	60	S 235 galvanised	50	3	K5116kt
16 x 70	43	38	5	S 8620	70		50	3	K5116kt

Permissible loads

Typical installation situation				Application as fastener			Application as lifting socket ²⁾	
Edge distance (c ₁), centre-to-centre spacing (s), panel thickness (h _{cr})			Concrete strength	Permissible loads ¹⁾			char. ultimate load N _{char,ult}	perm F _V ²⁾
				without additional reinforcement	with additional reinforcement			
[cm]			C	[kN]			[kN]	
c _{1,2,3,4}	s	h _{cr}		N _{Rd}	V _{Rd}	V _{Rd}		
40	80	5.5	20/25	17.0	13.0	15.4	25.5	12.1
40	80	5.5	20/25	19.5	13.0	15.5	29.3	14.0

1.) The permissible loads for the assumed installation situation were calculated with $\gamma = 1.5$. Adjustments will be necessary in the case of other edge conditions.

2.) Permissible loads from tests based on VDI/BV-BS 6205 (lifting inserts/systems for PCC elements) carried out in conjunction with TU Dortmund, Institute of Fastening Technology, plus test-based calculations. When used as a lifting socket, a factor of safety $\gamma = 2.1$ (method A) applies.

Design table

Horizontal and vertical elements and inclined pull in prop

Panel thk. h = 5.5 cm; edge distance c _{CR} = 40.0 cm; c/c spacing s _{CR} = 80.0 cm												
Angle α from the vertical	Design loads - CEN/TS 1992-4: Fastenings											
	no additional reinforcement						with additional reinforcement for shear					
	Concrete C20/25			Concrete C25/30			Concrete C20/25			Concrete C25/30		
	H _{Sd}	V _{Sd}	S _{Sd}	H _{Sd}	V _{Sd}	S _{Sd}	H _{Sd}	V _{Sd}	S _{Sd}	H _{Sd}	V _{Sd}	S _{Sd}
[kN]												
30°	5.8	10	11.6	5.9	10.3	11.9	6.4	11.1	12.8	7.1	12.3	14.2
45°	7.9	7.9	11.2	8.3	8.3	11.7	8.6	8.6	12.2	9.5	9.5	13.4

The table lists the maximum design loads for the given installation situation. The loads given above utilise the capacity of the socket to the full.

Custom versions on request.
Errors and omissions excepted.
Position as of Jan 2015

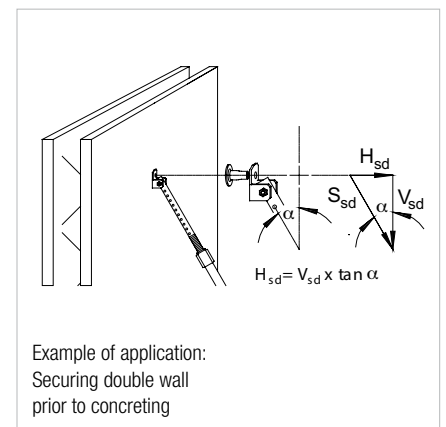
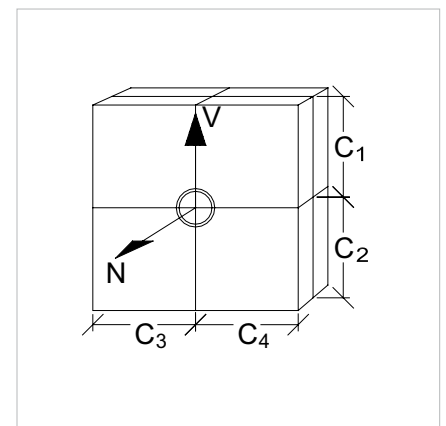

Example of application:
Securing double wall
prior to concreting

Installation situation

For pure tension loads without additional reinforcement, then:
- edge distance $\geq 1.5 \times (L-t) + 0.5 \times D$
- centre-to-centre spacing $\geq 3.0 \times (L-t) + D$
in order to achieve the full concrete pullout strength.

For simultaneous tension and shear forces, then:
 $N_{Sd}/N_{Rd} + V_{Sd}/V_{Rd} \leq 1.2$

Additional reinforcement for 90° pull
The additional reinforcement must press against the socket.
U-bar in grade B500B $d_s = 8$ mm,
Anchorage length $L = 170$ mm, $D_{min} = 32$ mm